



Count on it.

Operator's Manual

TX 1000 Compact Utility Loader

Model No. 22327—Serial No. 31500001 and Up

Model No. 22327G—Serial No. 31500001 and Up

Model No. 22328—Serial No. 31500001 and Up

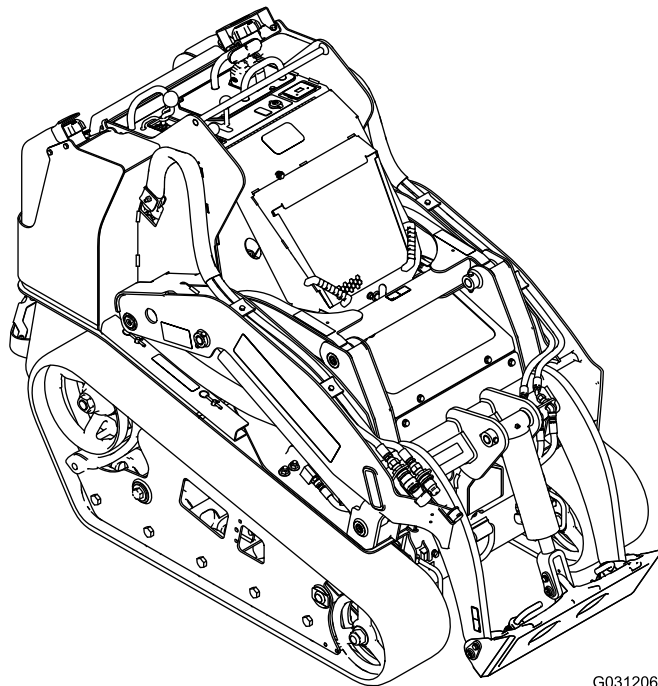

G031206



⚠ WARNING

CALIFORNIA Proposition 65 Warning

This product contains a chemical or chemicals known to the State of California to cause cancer, birth defects, or reproductive harm.

The engine exhaust from this product contains chemicals known to the State of California to cause cancer, birth defects, or other reproductive harm.

It is a violation of California Public Resource Code Section 4442 or 4443 to use or operate the engine on any forest-covered, brush-covered, or grass-covered land unless the engine is equipped with a spark arrester, as defined in Section 4442, maintained in effective working order or the engine is constructed, equipped, and maintained for the prevention of fire.

The enclosed engine owner's manual is supplied for information regarding the US Environmental Protection Agency (EPA) and the California Emission Control Regulation of emission systems, maintenance, and warranty. Replacements may be ordered through the engine manufacturer.

Introduction

This machine is a compact tool carrier intended to move various earth and materials for landscaping and construction work. It is designed to operate a wide variety of attachments each of which perform a specialized function.

Read this information carefully to learn how to operate and maintain your product properly and to avoid injury and product damage. You are responsible for operating the product properly and safely.

You may contact Toro directly at www.Toro.com for product safety and operation training materials, accessory information, help finding a dealer, or to register your product.

Whenever you need service, genuine Toro parts, or additional information, contact an Authorized Service Dealer or Toro Customer Service and have the model and serial numbers of your product ready. [Figure 1](#) identifies the location of the model and serial numbers on the product. Write the numbers in the space provided.

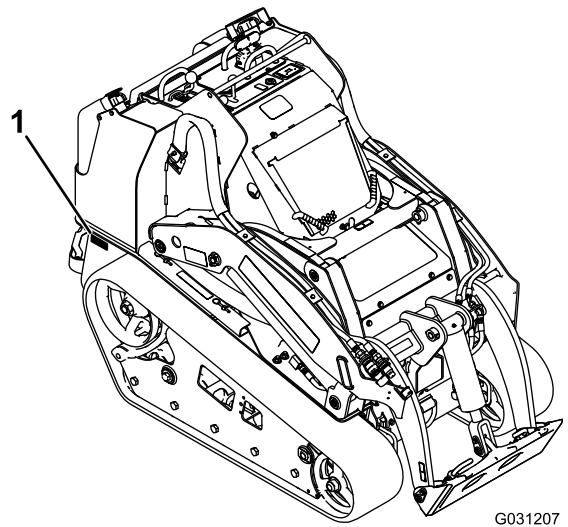

G031207

Figure 1

1. Model and serial number location

Model No. _____

Serial No. _____

This manual identifies potential hazards and has safety messages identified by the safety-alert symbol ([Figure 2](#)), which signals a hazard that may cause serious injury or death if you do not follow the recommended precautions.



Figure 2

1. Safety-alert symbol

This manual uses 2 words to highlight information.

Important calls attention to special mechanical information and **Note** emphasizes general information worthy of special attention.

Contents

Safety	4
Safe Operating Practices	4
Stability Data	7
Slope Indicator	8
Safety and Instructional Decals	9
Product Overview	13
Controls	13
Message Display	16
Specifications	17
Attachments/Accessories	17
Operation	18
Think Safety First	18
Adding Fuel	18
Filling the Fuel Tanks	19
Checking the Engine-Oil Level	20
Checking the Hydraulic Fluid Level	20
Checking the Engine Coolant	21
Bleeding the Fuel System	22
Starting and Stopping the Engine	22
Stopping the Machine	23
Moving a Non-functioning Machine	23
Using Attachments	23
Securing the Machine for Transport	25
Lifting the Machine	25
Maintenance	26
Recommended Maintenance Schedule(s)	26
Pre-maintenance Procedures	27
Using the Cylinder Lock	27
Opening the Hood	27
Closing the Hood	28
Opening the Rear-Access Cover	28
Removing the Front Screen	28
Removing the Side Screens	28
Lubrication	29
Greasing the Machine	29
Engine Maintenance	30
Servicing the Air Cleaner	30
Servicing the Engine Oil	31
Fuel System Maintenance	32
Checking the Fuel Lines and Connections	32
Draining the Fuel Filter/Water Separator	33
Replacing the Fuel Filter Canister and In-Line Filter	33
Draining the Fuel Tanks	33
Electrical System Maintenance	34
Servicing the Battery	34
Servicing the Fuses	35
Drive System Maintenance	35
Servicing the Tracks	35
Cooling System Maintenance	38
Servicing the Cooling System	38
Belt Maintenance	39
Checking the Alternator/Fan Belt Tension	39
Controls System Maintenance	39
Hydraulic System Maintenance	40
Replacing the Hydraulic Filter	40

Changing the Hydraulic Fluid	40
Checking the Hydraulic Lines	42
Cleaning	42
Removing Debris from the Traction Unit	42
Cleaning the Chassis	43
Storage	43
Troubleshooting	44
Schematics	48

Safety

Improper use or maintenance by the operator or owner can result in injury. To reduce the potential for injury, comply with these safety instructions and always pay attention to the safety-alert symbol **A**, which means: *Caution, Warning, or Danger*—personal safety instruction. Failure to comply with the instruction may result in personal injury or death.

Safe Operating Practices

This product is capable of amputating hands and feet. Always follow all safety instructions to avoid serious injury or death.

A WARNING

Engine exhaust contains carbon monoxide, an odorless, deadly poison that can kill you.

Do not run the engine indoors or in an enclosed area.

Training

- Read the *Operator's Manual* and other training material. If the operator(s) or mechanic(s) cannot read English, it is the owner's responsibility to explain this material to them.
- Become familiar with the safe operation of the equipment, operator controls, and safety signs.
- All operators and mechanics should be trained. The owner is responsible for training the users.
- Never let children or untrained people operate or service the equipment. Local regulations may restrict the age of the operator.
- The owner/user can prevent and is responsible for accidents or injuries occurring to himself or herself, other people or property.

Preparation

- Evaluate the terrain to determine what accessories and attachments are needed to properly and safely perform the job. Only use accessories and attachments approved by the manufacturer.
- Wear appropriate clothing including gloves, safety glasses, long pants, substantial slip-resistant footwear, and hearing protection. Tie back long hair and do not wear jewelry.
- Inspect the area where the equipment is to be used and remove all objects such as rocks, toys, and wire which can be thrown by the machine.
- Use extra care when handling fuels. They are flammable and vapors are explosive.
 - Use only an approved container
 - Never remove the fuel cap or add fuel with the engine running. Allow the engine to cool before refueling. Do not smoke.

- Never refuel or drain the machine indoors.

- Check that the operator's presence controls, safety switches, and shields are attached and functioning properly. Do not operate unless they are functioning properly.

Operation

- Only operate in good light, keeping away from holes and hidden hazards.
- Be sure all drives are in neutral and parking brake is engaged before starting the engine. Only start the engine from the operator's position.
- Slow down and use extra care on hillsides. Be sure to travel in the recommended direction on hillsides. Turf conditions can affect the machine's stability.
- Slow down and use caution when making turns, crossing roads and sidewalks, and changing directions on slopes.
- Never operate without the guards securely in place. Be sure all interlocks are attached, adjusted, and functioning properly.
- Do not change the engine governor setting or overspeed the engine.
- Stop on level ground, lower implements, disengage the auxiliary hydraulics, engage parking brake, shut off the engine before leaving the operator's position for any reason.
- Keep hands and feet away from moving attachments.
- Look behind and down before backing up to be sure of a clear path.
- Never carry passengers and keep pets and bystanders away.
- Slow down and use caution when making turns and crossing roads and sidewalks.
- Do not operate the machine when you are tired, ill, or under the influence of alcohol or drugs.
- Use care when loading or unloading the machine into a trailer or truck.
- Use care when approaching blind corners, shrubs, trees, or other objects that may obscure vision.
- Read all attachment manuals.
- Ensure that the area is clear of other people before operating the traction unit. Stop the traction unit if anyone enters the area.
- Never leave a running traction unit unattended. Always lower the loader arms, stop the engine, set the parking brake, and remove the key before leaving.
- Do not exceed the rated operating capacity, as the traction unit may become unstable which may result in loss of control.
- Do not carry a load with the arms raised. Always carry loads close to the ground.

- Do not overload the attachment and always keep the load level when raising the loader arms. Logs, boards, and other items could roll down the loader arms, injuring you.
- Never jerk the controls; use a steady motion.
- Watch for traffic when operating near or crossing roadways.
- Do not touch parts which may be hot from operation. Allow them to cool before attempting to maintain, adjust, or service.
- Check for overhead clearances (i.e., branches, doorways, electrical wires) before driving under any objects and do not contact them.
- Ensure that you operate the traction unit in areas where there are no obstacles in close proximity to the operator. Failure to maintain adequate distance from trees, walls, and other barriers may result in injury. Only operate the unit in areas where there is sufficient clearance for the operator to safely maneuver the product.
- Before digging, have the area marked for underground utilities, and do not dig in marked areas.
Also, be aware of the location of objects and structures that may not be marked, such as underground storage tanks, wells, and septic systems.
- Locate the pinch point areas marked on the traction unit and attachments and keep hands and feet away from these areas.
- Before operating the traction unit with an attachment, ensure that the attachment is properly installed and a genuine Toro attachment.
- Lightning can cause severe injury or death. If lightning is seen or thunder is heard in the area, do not operate the machine; seek shelter.

Slope Operation

Slopes are a major factor related to loss-of-control and tip-over accidents, which can result in severe injury or death. All slopes require extra caution.

- Do not operate the traction unit on hillsides or slopes exceeding the angles recommended in [Stability Data \(page 7\)](#), and those in the attachment *Operator's Manual*. See also the [Slope Indicator \(page 8\)](#).
- **Operate up and down slopes with the heavy end of the traction unit uphill.** Weight distribution changes. An empty bucket will make the rear of the traction unit the heavy end, and a full bucket will make the front of the traction unit the heavy end. Most other attachments will make the front of traction unit the heavy end.
- Raising the loader arms on a slope will affect the stability of the machine. Whenever possible, keep the loader arms in the lowered position when on slopes.
- Removing an attachment on a slope will make the rear of the traction unit heavy. Refer to [Stability Data \(page 7\)](#), to determine whether the attachment can be safely removed on the slope.
- Remove obstacles such as rocks, tree limbs, etc. from the work area. Watch for holes, ruts, or bumps, as uneven terrain could overturn the traction unit. Tall grass can hide obstacles.
- Use only Toro-approved attachments. Attachments can change the stability and the operating characteristics of the traction unit. Warranty may be voided if used with unapproved attachments.
- Keep all movements on slopes slow and gradual. Do not make sudden changes in speed or direction.
- Avoid starting or stopping on a slope. If the traction unit loses traction, proceed slowly, straight down the slope.
- Avoid turning on slopes. If you must turn, turn slowly and keep the heavy end of the traction unit uphill.
- Do not operate near drop-offs, ditches, or embankments. The traction unit could suddenly turn over if a track goes over the edge of a cliff or ditch, or if an edge caves in.
- Use caution when operating on wet grass. Reduced traction could cause sliding.
- Do not park the traction unit on a hillside or slope without lowering the attachment to the ground, setting the parking brake, and chocking the tracks.

Maintenance and Storage



- Disengage the auxiliary hydraulics, lower the attachment, set the parking brake, stop the engine, and remove the key. Wait for all movement to stop and the unit to cool before adjusting, cleaning, or repairing.
- Clean debris from attachments, drives, mufflers, and engine to help prevent fires. Clean up oil or fuel spillage.
- Let the engine cool before storing and do not store near flame.
- Do not store fuel near flames or drain indoors.
- Park the machine on level ground. Never allow untrained personnel to service the machine.
- Use jack stands to support components when required.
- Carefully release pressure from components with stored energy.
- Disconnect the battery before making any repairs. Disconnect the negative terminal first and the positive last. Reconnect positive first and negative last.
- Keep hands and feet away from moving parts. If possible, do not make adjustments with the engine running.
- Charge batteries in an open well ventilated area, away from spark and flames. Unplug the charger before connecting or disconnecting it from the battery. Wear protective clothing and use insulated tools.
- Keep all parts in good working condition and all hardware tightened. Replace all worn or damaged decals.
- If any maintenance or repair requires the loader arms to be in the raised position, secure the arms in the raised position with the hydraulic cylinder lock.



- Secure the loader arm valve with the loader valve lock anytime you need to stop the machine with the loader arms raised.
- Keep nuts and bolts tight. Keep equipment in good condition.
- Never tamper with safety devices.
- Keep the traction unit free of grass, leaves, or other debris build-up. Clean up oil or fuel spillage. Allow the traction unit to cool before storing.
- Use extra care when handling fuels. They are flammable and vapors are explosive.
 - Use only an approved container.
 - Never remove the fuel cap or add fuel when the engine is running. Allow the engine to cool before refueling. Do not smoke.
 - Never refuel the traction unit indoors.
 - Never store the traction unit or fuel container inside where there is an open flame, such as near a water heater or furnace.
 - Never fill a container while it is inside a vehicle, trunk, pick-up bed, or any surface other than the ground.
 - Keep container nozzle in contact with the tank during filling.
- Stop and inspect the equipment if you strike an object. Make any necessary repairs before restarting.
- Use only genuine Toro replacement parts to ensure that original standards are maintained.
- Battery acid is poisonous and can cause burns. Avoid contact with skin, eyes, and clothing. Protect your face, eyes, and clothing when working with a battery.
- Battery gases can explode. Keep cigarettes, sparks and flames away from the battery.
- Keep your body and hands away from pin hole leaks or nozzles that eject high pressure hydraulic fluid. Use cardboard or paper to find hydraulic leaks; never use your hands. Hydraulic fluid escaping under pressure can penetrate skin and cause injury requiring surgery within a few hours by a qualified surgeon or gangrene may result.

Stability Data

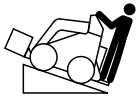
The following tables list the maximum slope recommended for the traction unit in the positions listed in the tables. Slopes over the listed degree may cause the traction unit to become unstable. The data in the tables assume that the loader arms are fully lowered; raised arms may affect the stability.

In each attachment manual is a set of three stability ratings, one for each hill position. To determine the maximum slope you can traverse with the attachment installed, find the degree of slope that corresponds to the stability ratings of the attachment. Example: If the attachment installed on a TX model 22327 traction unit has a Front Uphill rating of B, a Rear Uphill rating of D, and a Side Uphill rating of C, then you could drive forward up a 19° slope, rearward up a 11° slope, or sideways on a 11° slope, as listed in the following table.

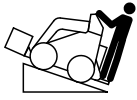
Model 22327			
Configuration	Maximum Recommended Slope when Operating with:		
	Front Uphill	Rear Uphill	Side Uphill
			
Traction unit without attachment	15°	19°	16°
Traction unit with an attachment rated with one of the following stability ratings for each slope position:*			
A	25°	25°	20°
B	19°	20°	15°
C	16°	17°	11°
D	14°	11°	8°
E	5°	5°	5°

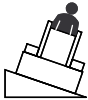
Model 22328			
Configuration	Maximum Recommended Slope when Operating with:		
	Front Uphill	Rear Uphill	Side Uphill
			
Traction unit without attachment	16°	19°	19°
Traction unit with an attachment rated with one of the following stability ratings for each slope position:*			
A	25°	25°	23°
B	21°	19°	18°
C	18°	15°	14°
D	15°	10°	10°
E	5°	5°	5°

Slope Indicator

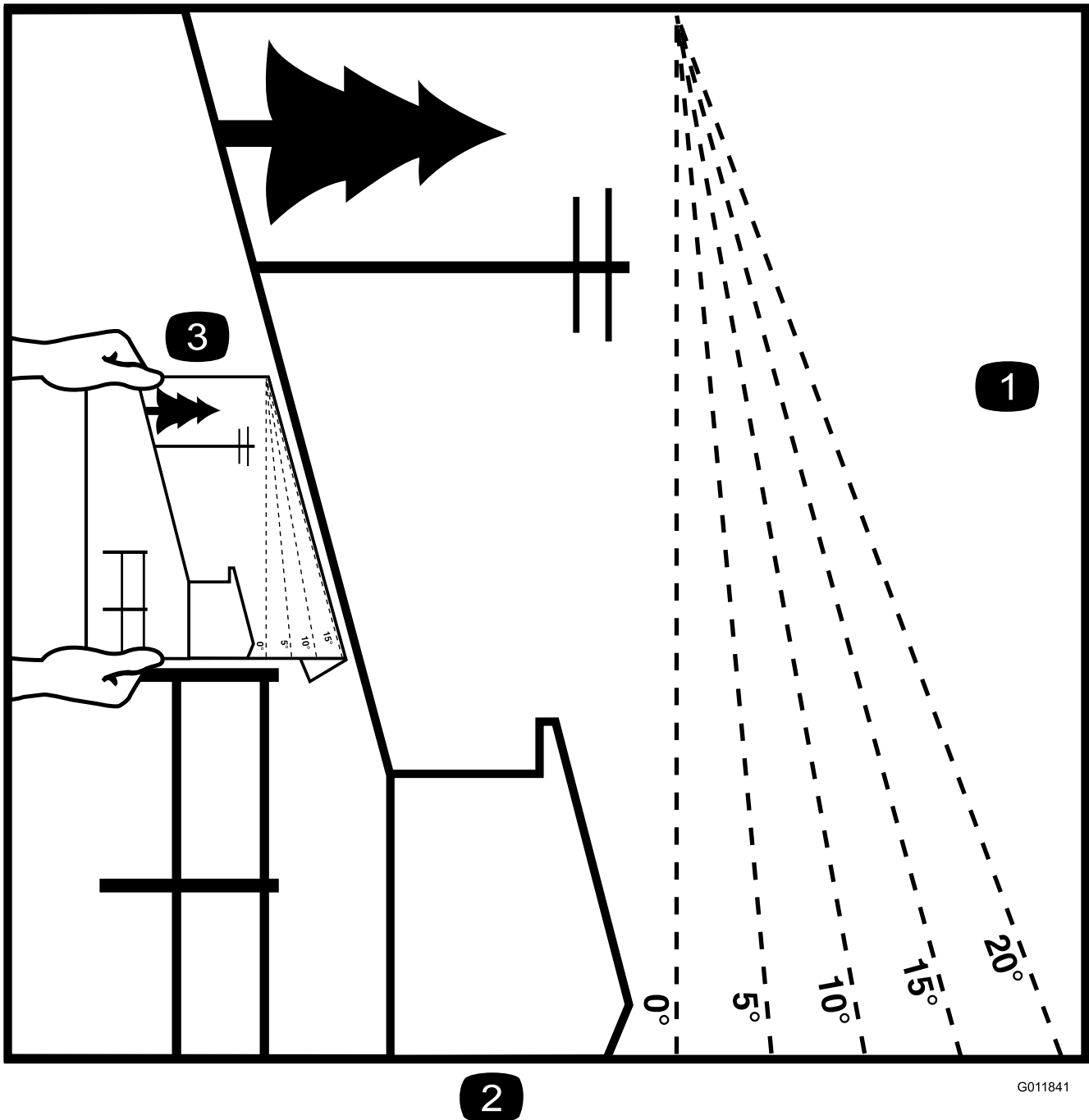

G011841

2

Figure 3

This page may be copied for personal use.

1. To determine the maximum slope you can safely operate the machine on, refer to the Stability Data section. Use the slope indicator to determine the degree of slope of hills before operating. **Do not operate this machine on a slope greater than that specified in the Stability Data section.** Fold along the appropriate line to match the recommended slope.
2. Align this edge with a vertical surface, a tree, building, fence pole, etc.
3. Example of how to compare slope with folded edge.

Safety and Instructional Decals



Safety decals and instructions are easily visible to the operator and are located near any area of potential danger. Replace any decal that is damaged or lost.

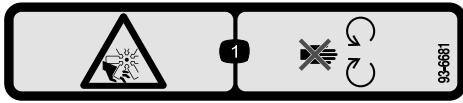

93-6681

1. Cutting/dismemberment hazard, fan—stay away from moving parts.



115-2047

1. Warning—do not touch the hot surface.

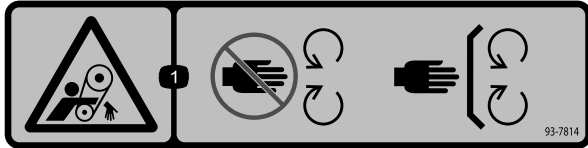

93-7814

1. Entanglement hazard, belt—stay away from moving parts.

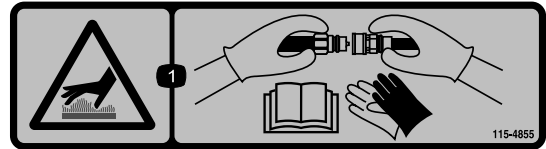

115-4855

1. Hot surface/burn hazard—wear protective gloves when handling the hydraulic couplers and read the *Operator's Manual* for information on handling hydraulic components.

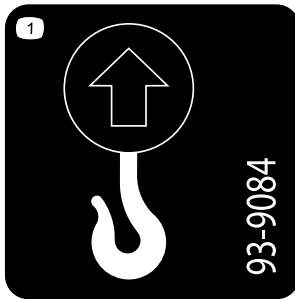

93-9084

1. Lift point
2. Tie-down point



115-4858

1. Crushing hazard of hands or feet—install the cylinder lock.



115-4865

1. Engine coolant
2. Read the *Operator's Manual*.



106-6755

1. Engine coolant under pressure.
2. Explosion hazard—read the *Operator's Manual*.
3. Warning—do not touch the hot surface.
4. Warning—read the *Operator's Manual*.



117-2718

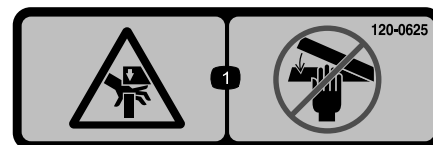

120-0625

1. Pinch point, hand—keep hands away.

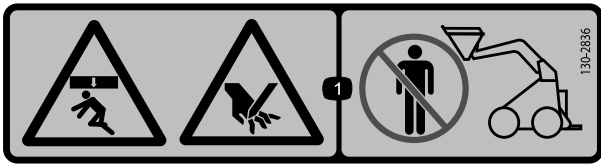

130-2836

1. Crushing hazard; cutting hazard—keep away from the bucket and the lift arm.

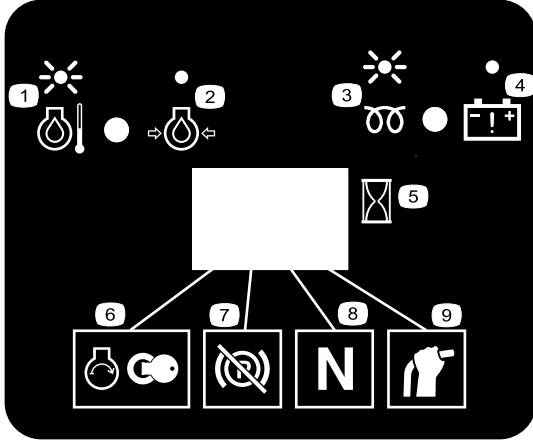

130-7637

- | | |
|--|-----------------------------|
| 1. Blinking light—engine-coolant temperature | 6. Engine start |
| 2. Steady light—engine-oil pressure | 7. Parking brake disengaged |
| 3. Blinking light—glow plug | 8. Traction neutral |
| 4. Steady light—battery warning | 9. Auxiliary lever neutral |
| 5. Hourmeter | |



131-0709

1. Parking brake—engage
2. Parking brake—disengage

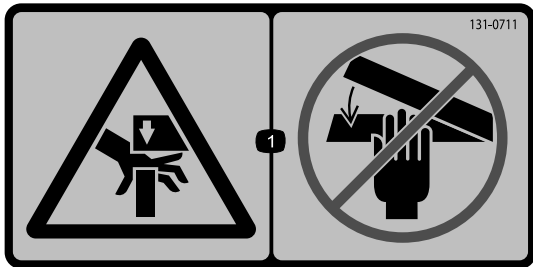

131-0711

1. Crushing hazard—keep away from pinch points and actuating parts.



Battery Symbols

Some or all of these symbols are on your battery

- | | |
|--|--|
| 1. Explosion hazard | 6. Keep bystanders a safe distance from the battery. |
| 2. No fire, open flame, or smoking. | 7. Wear eye protection; explosive gases can cause blindness and other injuries |
| 3. Caustic liquid/chemical burn hazard | 8. Battery acid can cause blindness or severe burns. |
| 4. Wear eye protection | 9. Flush eyes immediately with water and get medical help fast. |
| 5. Read the <i>Operator's Manual</i> . | 10. Contains lead; do not discard. |

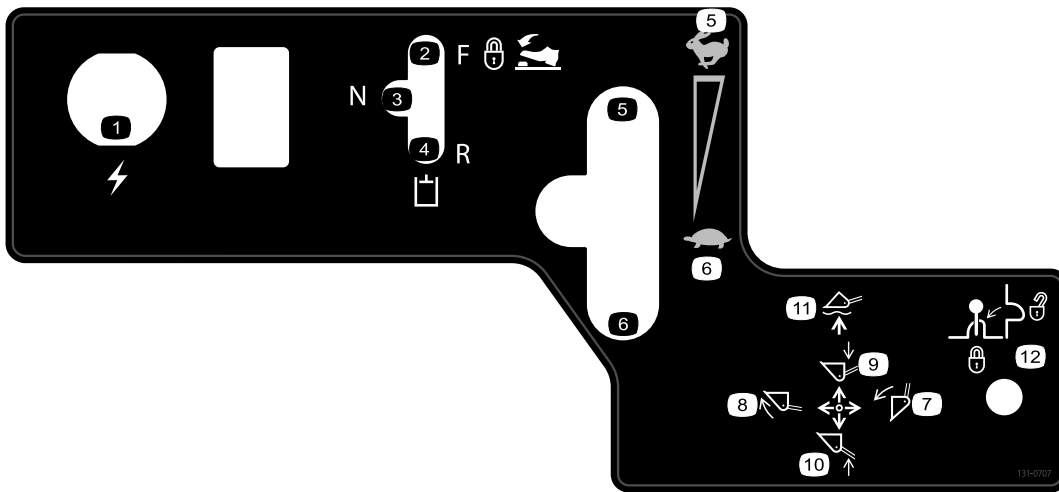

131-0707

- | | |
|--|--|
| <ol style="list-style-type: none"> 1. 12 V power socket 2. Hydraulic attachment—forward operation 3. Hydraulic attachment—neutral position 4. Hydraulic attachment—reverse operation 5. Engine speed—fast 6. Engine speed—slow | <ol style="list-style-type: none"> 7. Tilt the attachment forward. 8. Tilt the attachment rearward. 9. Lower the attachment. 10. Raise the attachment. 11. Move the attachment to a float position. 12. Lever lock |
|--|--|

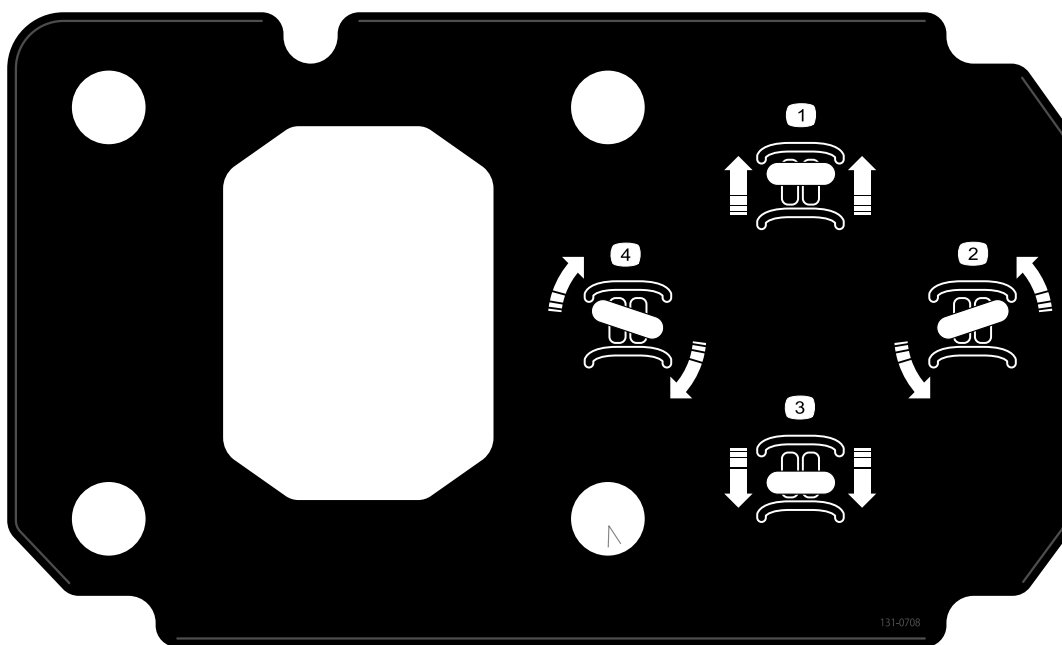

131-0708

- | | |
|--|--|
| <ol style="list-style-type: none"> 1. Move forward 2. Turn right | <ol style="list-style-type: none"> 3. Move rearward 4. Turn left |
|--|--|



131-0710

1. Warning—read the *Operator's Manual*.
2. Warning—receive training before operating the machine.
3. Warning—wear hearing protection.
4. Warning—engage the parking brake, lower the bucket to the ground, stop the engine, and remove the key from the ignition before leaving the machine.
5. Electrocutation hazard, power lines—check for power lines in the area before using the machine.
6. Crushing hazard—keep away from pinch points; read the *Operator's Manual* before servicing or performing maintenance.
7. Cutting/severing hazard of hand or foot—wait for all moving parts to stop before servicing; keep away from moving parts; keep all guards and shields in place.
8. Explosion hazard; electrocution hazard—call the local utilities hotline before beginning work in an area.
9. Crushing hazard—keep away from the bucket when operating the machine; keep bystanders away from the machine.
10. Tipping hazard—always move up or down slopes with the bucket lowered; never drive on a slope with the bucket raised.
11. Tipping hazard—do not make fast turns; always check behind you before reversing the machine.

Product Overview

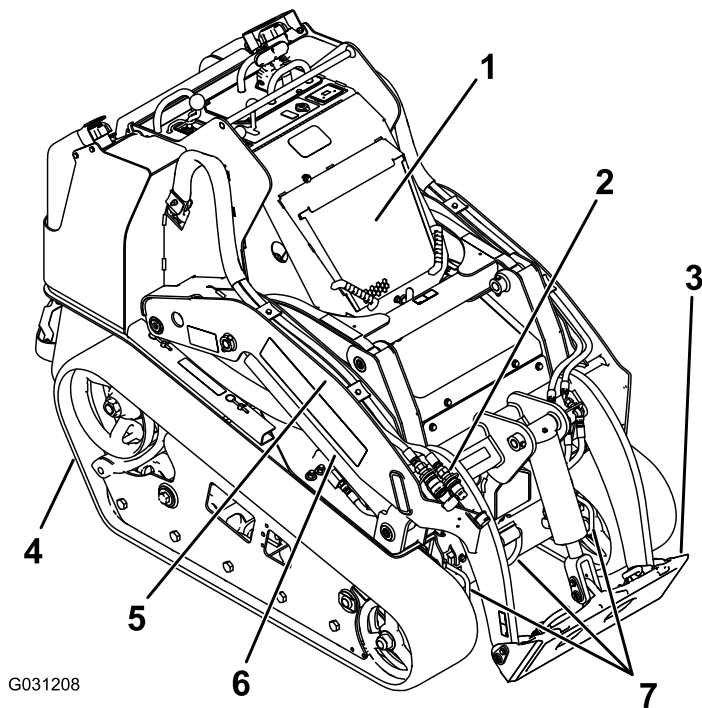

G031208

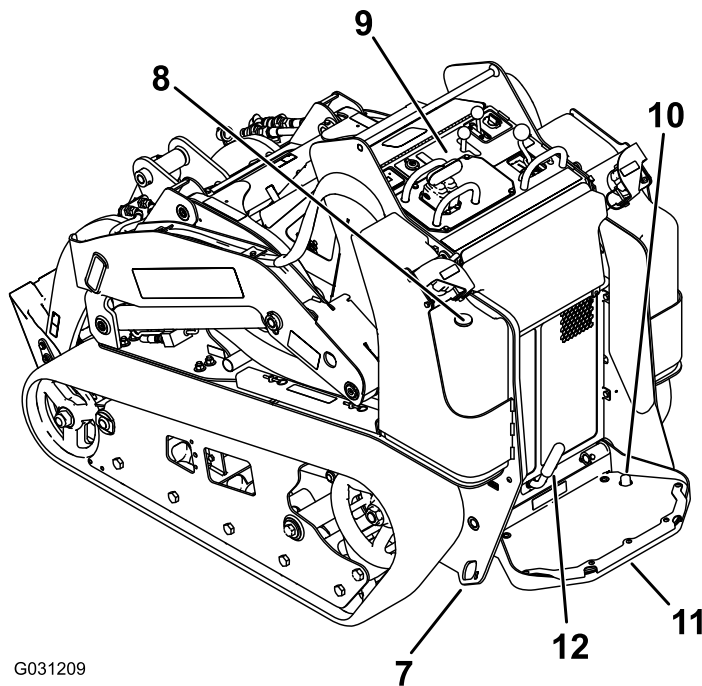

G031209

Figure 4

- | | |
|---------------------------------|--------------------------------------|
| 1. Hood | 7. Tie-down/lift loop |
| 2. Auxiliary-hydraulic couplers | 8. Fuel gauge |
| 3. Mount plate | 9. Control panel |
| 4. Track | 10. Auxiliary-hydraulics-lock switch |
| 5. Loader arm | 11. Operator platform |
| 6. Lift cylinder | 12. Parking brake |

Controls

Become familiar with all the controls ([Figure 5](#)) before you start the engine and operate the traction unit.

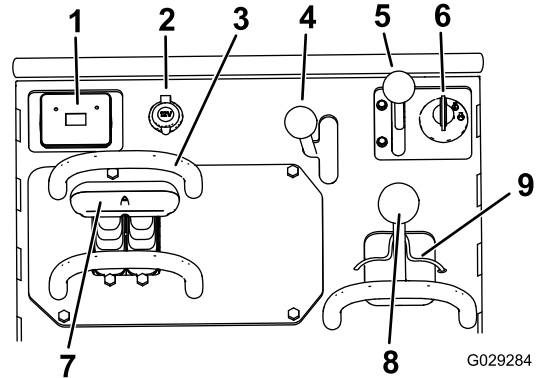

G029284

Figure 5

- | | |
|-------------------------------|-------------------------------------|
| 1. Message display | 6. Key switch |
| 2. Power socket | 7. Traction control |
| 3. Reference bar | 8. Loader arm/attachment-tilt lever |
| 4. Auxiliary-hydraulics lever | 9. Loader lock |
| 5. Throttle lever | |

Key Switch

The key switch, used to start and stop the engine, has 3 positions: OFF, RUN, and START.

To start the engine, rotate the key to the START position. Release the key when engine starts and it will move automatically to the RUN position.

To stop the engine, rotate the key to the OFF position.

Throttle Lever

Move the control forward to increase the engine speed and rearward to decrease speed.

Reference Bar

When driving the traction unit, use the reference bar as a handle and a leverage point for controlling the traction control and the auxiliary-hydraulics lever. To ensure smooth, controlled operation, do not take both hands off the reference bar while operating the machine.

Traction Control

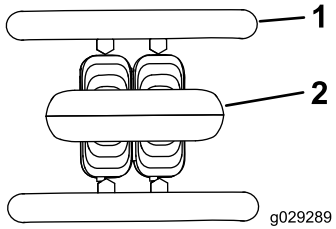

Figure 6

1. Reference bar
2. Traction control

- To turn right, rotate the traction control clockwise (Figure 9).

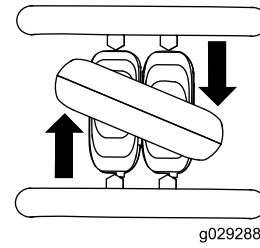

Figure 9

- To turn left, rotate the traction control counterclockwise (Figure 10).

- To move forward, move the traction control forward (Figure 7).

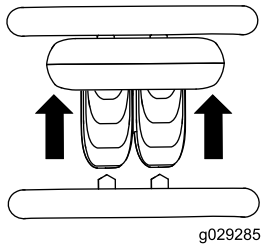

Figure 7

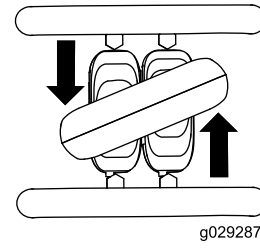

Figure 10

- To move rearward, move the traction control rearward (Figure 8).

Important: When reversing, look behind you for obstructions and keep your hands on the reference bar.

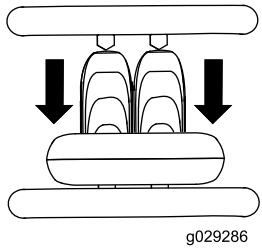

Figure 8

- To stop, release the traction control (Figure 6).

Note: The farther you move the traction control in any direction, the faster the machine moves in that direction.

Loader Arm/Attachment-Tilt Lever

- To tilt the attachment forward, slowly move the lever to the right (Figure 11).
- To tilt the attachment rearward, slowly move the lever to the left (Figure 11).
- To lower the loader arms, slowly move the lever forward (Figure 11).
- To raise the loader arms, slowly move the lever rearward (Figure 11).
- To lower the loader arms to a detent (float) position, push the lever fully forward (Figure 11).

Note: This allows attachments such as the leveler and the hydraulic blade to follow the contours of the ground (i.e., float) when grading.

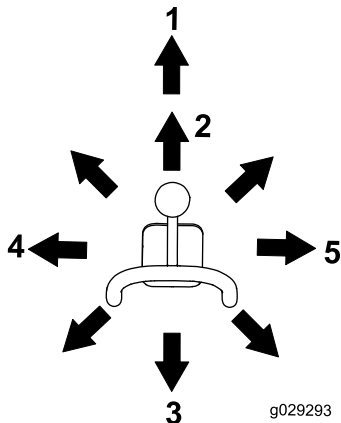

Figure 11

- | | |
|----------------------------|----------------------------------|
| 1. Detent (float) position | 4. Tilt the attachment rearward. |
| 2. Lower the loader arms. | 5. Tilt the attachment forward. |
| 3. Raise the loader arms. | |

By moving the lever to an intermediate position (e.g., forward and left), you can move the loader arms and tilt the attachment at the same time.

Loader Lock

The loader lock secures the loader arm/attachment-tilt lever so that you cannot push it forward. This ensures that no one accidentally lowers the loader arms during maintenance. Secure the loader arms with the lock any time you need to stop the machine with the loader arms raised.

To set the lock, lift up on it so it clears the hole in the control panel and swing it to the left, in front of the loader-arm lever, pushing it down into the locked position (Figure 12).

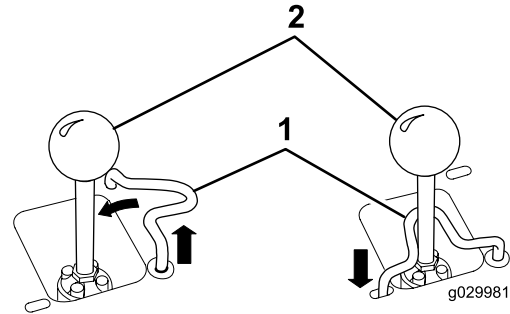

Figure 12

Loader-Control Reference Bar

The loader-control reference bar helps stabilize your hand while operating the loader arm/attachment tilt lever (Figure 4).

Auxiliary-Hydraulics Lever

To operate a hydraulic attachment in the forward direction, move the auxiliary-hydraulics lever forward (Figure 13).

To operate a hydraulic attachment in reverse direction, move the hydraulics lever rearward (Figure 13).

If you release the lever while in the FORWARD or REVERSE position, the lever automatically returns to the NEUTRAL position (Figure 13).

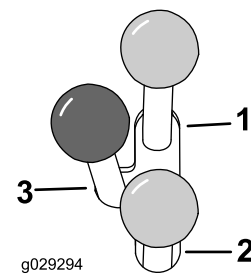

Figure 13

- | | |
|----------------------------|------------|
| 1. Forward flow hydraulics | 3. Neutral |
| 2. Reverse flow hydraulics | |

Auxiliary-Hydraulics-Lock Switch

Press the auxiliary-hydraulics-lock switch to lock the auxiliary-hydraulics lever in the FORWARD position and free your hand for other controls (Figure 5).

Parking Brake Lever

To set the parking brake, rotate the brake lever to left (Figure 14).

Note: The traction unit may roll slightly before the brakes engage in the drive sprocket.

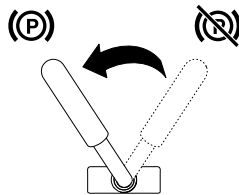

Figure 14

To release the brake, rotate the brake lever to the right.

Note: You may need to adjust the traction control to release the brake pins and rotate the lever.

Fuel Gauge

This gauge measures the amount of fuel in the fuel tanks (Figure 4).

Message Display

Engine-Coolant Temperature

If the engine coolant becomes too hot, the light on the left flashes and the horn sounds (Figure 15). If this happens, disengage the auxiliary hydraulics and let the machine run at high idle to allow the cooling system to cool the machine. Check the coolant level when the engine has fully cooled.

Important: Do not shut off the engine, as this may cause the machine to overheat.

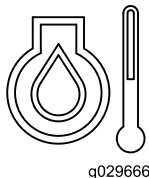

Figure 15

Engine-Oil Pressure

If the engine-oil-pressure becomes too low, the light on the left illuminates steadily (Figure 16). If this happens, shut off the engine immediately and check the oil. If the oil level is low, add oil and/or look for possible leaks.

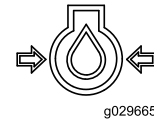

Figure 16

Glow Plug

The light on the right flashes while the glow plugs are charged and warming the engine (Figure 17).

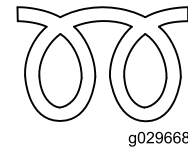

Figure 17

Battery-Charge Indicator Light

If the battery charge becomes too low, the light on the right illuminates steadily (Figure 18). If this happens, shut off the engine and charge or replace the battery. Refer to [Servicing the Battery](#) (page 34)

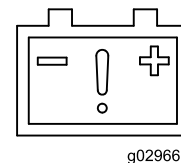

Figure 18

Hour Meter

The hour meter displays the number of hours of operation that have been logged on the traction unit and the following indicators:

- Engine start—displays when you start the engine



Figure 19

- Parking brake—displays when you disengage the parking brake



g030520
Figure 20

- Traction neutral—displays when the traction control is in the NEUTRAL position



g029211
Figure 21

- Auxiliary lever neutral—displays when the auxiliary lever is in the NEUTRAL position



g029975
Figure 22

Specifications

Note: Specifications and design are subject to change without notice.

Model 22327	
Width	84.8 cm (33.4 inches)
Length	255.8 cm (100.7 inches)
Height	138.2 cm (54.4 inches)
Weight	1234 kg (2720 lb)
Operating capacity (with standard bucket)	454 kg (1000 lb)
Tipping capacity (with standard bucket)	1296 kg (2857 lb)
Wheelbase	41 inches
Dump height (with standard bucket)	61 inches
Reach—fully raised (with standard bucket)	24.5 inches
Height to hinge pin (with standard bucket in highest position)	81 inches

Model 22328	
Width	102.9 cm (40.5 inches)
Length	255.8 cm (100.7 inches)
Height	138.2 cm (54.4 inches)
Weight	1297 kg (2860 lb)
Operating capacity (with standard bucket)	454 kg (1000 lb)
Tipping capacity (with standard bucket)	1296 kg (2857 lb)
Wheelbase	41 inches
Dump height (with standard bucket)	61 inches
Reach—fully raised (with standard bucket)	24.5 inches
Height to hinge pin (with standard bucket in highest position)	81 inches

Attachments/Accessories

A selection of Toro approved attachments and accessories is available for use with the machine to enhance and expand its capabilities. Contact your Authorized Service Dealer or Distributor or go to www.Toro.com for a list of all approved attachments and accessories.

Important: Use only Toro-approved attachments. Other attachments may create an unsafe operating environment or damage the traction unit.

Operation

Note: Determine the left and right sides of the machine from the normal operating position.

Important: Before operating, check the fuel and oil level, and remove debris from the traction unit. Ensure that the area is clear of people and debris. You should also know and have marked the locations of all utility lines.

Think Safety First

Carefully read all safety instructions and symbols in the safety section. Knowing this information could help you or bystanders avoid injury.

⚠ CAUTION

This machine produces sound levels that can cause hearing loss through extended periods of exposure.

Wear hearing protection when operating this machine.

⚠ CAUTION

Long-term exposure to vibration while operating the machine may cause some numbness in the hands and wrists.

Wear gloves that dampen the vibration whenever you operate the machine for an extended period of time.

The use of protective equipment for eyes, ears, hands, feet, and head is recommended.

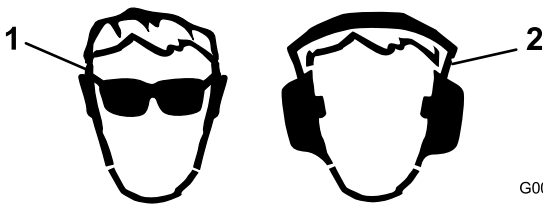

Figure 23

1. Wear safety glasses.
2. Wear hearing protection.

Adding Fuel

Use only clean, fresh diesel fuel or biodiesel fuels with low (<500 ppm) or ultra low (<15 ppm) sulfur content. The minimum cetane rating should be 40. Purchase fuel in quantities that can be used within 180 days to ensure fuel freshness.

Fuel tank capacity: 41 L (11 US gallons)

Use summer grade diesel fuel (No. 2-D) at temperatures above -7°C (20°F) and winter grade (No. 1-D or No. 1-D/2-D blend) below that temperature. Use of winter grade fuel at lower temperatures provides lower flash point and cold flow characteristics which will ease starting and reduce fuel filter plugging.

Use of summer grade fuel above -7°C (20°F) will contribute toward longer fuel pump life and increased power compared to winter grade fuel.

Important: Do not use kerosene or gasoline instead of diesel fuel. Failure to observe this caution will damage the engine.

⚠ WARNING

Fuel is harmful or fatal if swallowed. Long-term exposure to vapors can cause serious injury and illness.

- Avoid prolonged breathing of vapors.
- Keep face away from nozzle and fuel tank or conditioner opening.
- Keep fuel away from eyes and skin.

Biodiesel Ready

This machine can also use a biodiesel blended fuel of up to B20 (20% biodiesel, 80% petrodiesel). The petrodiesel portion should be low or ultra low sulfur. Observe the following precautions:

- The biodiesel portion of the fuel must meet specification ASTM D6751 or EN14214.
- The blended fuel composition should meet ASTM D975 or EN590.
- Painted surfaces may be damaged by biodiesel blends.
- Use B5 (biodiesel content of 5%) or lesser blends in cold weather.
- Monitor seals, hoses, gaskets in contact with fuel as they may be degraded over time.
- Fuel filter plugging may be expected for a time after converting to biodiesel blends.
- Contact your distributor if you wish for more information on biodiesel.

Filling the Fuel Tanks

▲ DANGER

In certain conditions, fuel is extremely flammable and highly explosive. A fire or explosion from fuel can burn you and others and can damage property.

- Fill the fuel tanks outdoors, in an open area, when the engine is cold. Wipe up any fuel that spills.
- Never fill the fuel tanks inside an enclosed trailer.
- Never smoke when handling fuel and stay away from an open flame or where fuel fumes may be ignited by a spark.
- Store fuel in an approved container and keep it out of the reach of children. Never buy more than a 30-day supply of fuel.
- Do not operate without entire exhaust system in place and in proper working condition.

▲ DANGER

In certain conditions during fueling, static electricity can be released, causing a spark that can ignite the fuel vapors. A fire or explosion from fuel can burn you and others and can damage property.

- Always place fuel containers on the ground away from your vehicle before filling.
- Do not fill fuel containers inside a vehicle or on a truck or trailer bed, because interior carpets or plastic truck bed liners may insulate the container and slow the loss of any static charge.
- When practical, remove equipment from the truck or trailer and refuel the equipment with its wheels on the ground.
- If this is not possible, then refuel such equipment on a truck or trailer from a portable container rather than from a fuel-dispenser nozzle.
- If you must use a fuel-dispenser nozzle, keep the nozzle in contact with the rim of the fuel tank or container opening at all times until fueling is complete.

Fill the fuel tanks as shown in [Figure 24](#).

Note: The fuel-tank caps click when you close them securely. Use the brackets to lock the fuel tanks.

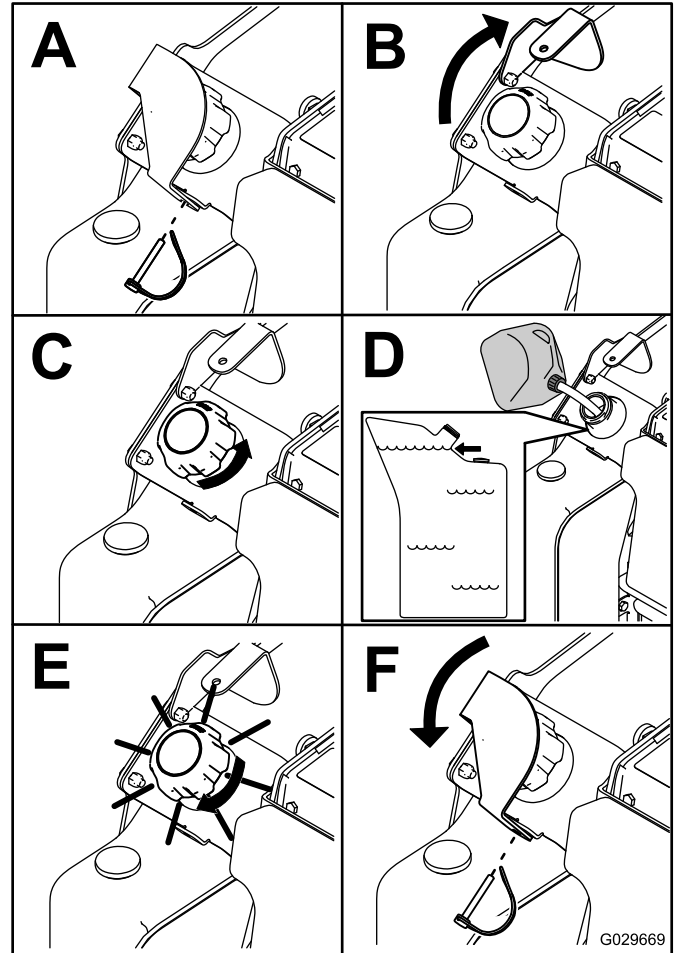

Figure 24

Checking the Engine-Oil Level

Service Interval: Before each use or daily

1. Park the traction unit on a level surface, lower the loader arms, and shut off the engine.
2. Remove the key and allow the engine to cool.
3. Open the hood and secure the hood prop.
4. Clean around the oil dipstick and oil-filler cap (Figure 25).

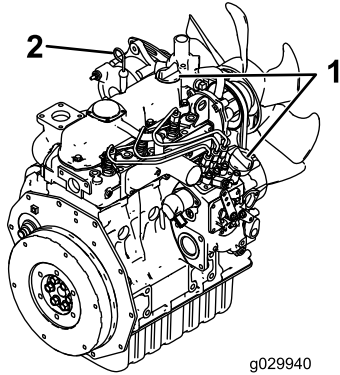

Figure 25

1. Oil-filler cap
2. Oil dipstick

5. Check the oil and add additional oil as needed (Figure 26).

Important: Do not overfill the crankcase with oil because the engine may be damaged.

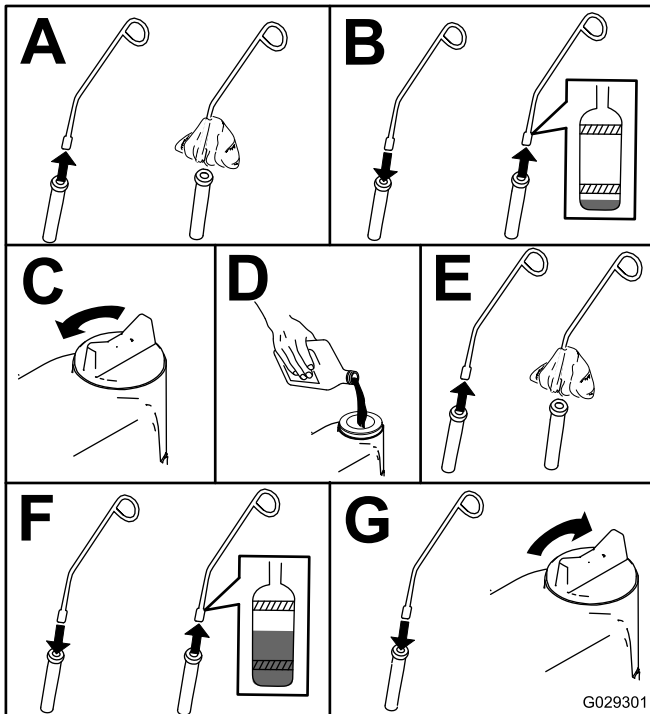

Figure 26

Checking the Hydraulic Fluid Level

Service Interval: Every 25 hours

Hydraulic Tank Capacity: 37.9 L (10 US gallons)

Refer to [Changing the Hydraulic Fluid \(page 40\)](#) for hydraulic fluid specifications.

Important: Always use the correct hydraulic fluid. Unspecified fluids will damage the hydraulic system.

1. Remove the attachment, if one is installed; refer to [Removing an Attachment \(page 24\)](#).
2. Park the traction unit on a level surface, shut off the engine, and remove the key.
3. Open the hood and secure the hood prop.
4. Remove the right side screen; refer to [Removing the Side Screens \(page 28\)](#).
5. Clean the area around the filler neck of the hydraulic tank (Figure 27).

Note: Raising the loader arms may improve your access to the hydraulic-tank cap. Install the cylinder lock if you raise the arms; refer to [Installing the Cylinder Lock \(page 27\)](#).

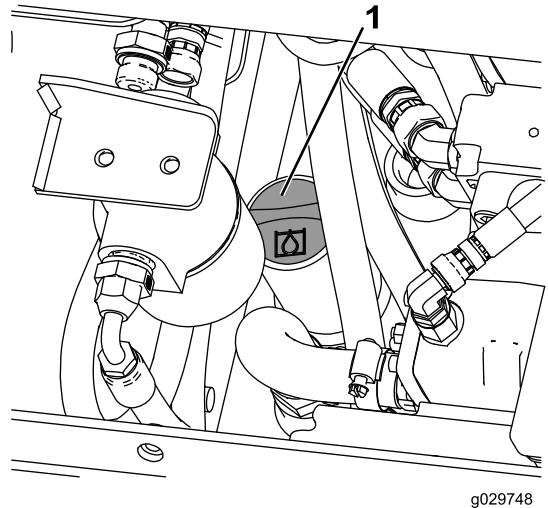

Figure 27

1. Hydraulic filler-neck cap

6. Remove the cap from the filler neck and check the fluid level on the dipstick (Figure 28).

Note: The fluid level should be between the 2 notches of the dipstick while the arms are lowered or at the lower notch while the arms are raised.

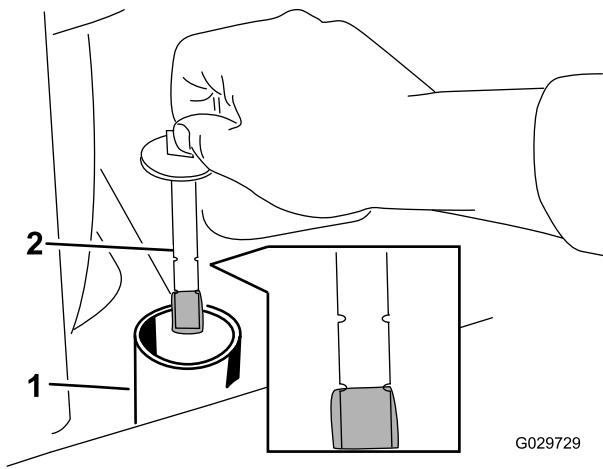

Figure 28

1. Filler neck 2. Dipstick

7. If the level is low, add enough fluid to raise it to the proper level.
8. Install the cap on the filler neck.
9. Install the side screen.
10. Close the hood.

Checking the Engine Coolant

Service Interval: Before each use or daily

Before each use or daily—Clean the screen, oil cooler, and front of the radiator (more often in dirty or dusty conditions).

The cooling system is filled with a 50/50 solution of water and permanent ethylene-glycol antifreeze.

⚠ DANGER

If the engine has been running, the pressurized, hot coolant can escape and cause severe burns.

- **Do not remove the radiator cap when the engine is hot. Always allow the engine to cool at least 15 minutes or until the radiator cap is cool enough to touch without burning your hand before removing the radiator cap.**
- **Do not touch radiator and surrounding parts that are hot.**
- **Use a rag when opening the radiator cap and open the cap slowly to allow steam to escape.**

⚠ DANGER

Rotating shaft and fan can cause personal injury.

- **Do not operate the machine without the covers in place.**
- **Keep fingers, hands, and clothing clear of rotating fan and drive shaft.**
- **Shut off the engine and remove the ignition key before performing maintenance.**

1. Check the level of coolant in the expansion tank (Figure 29).

Note: The coolant level should be at or above the mark on the side of the tank.

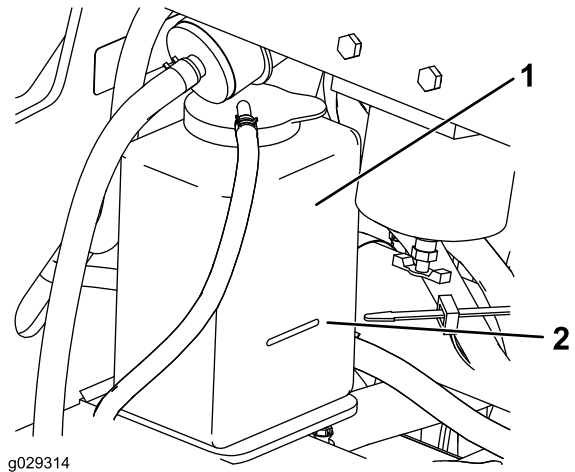

Figure 29

1. Expansion tank
2. Full mark

2. If the coolant level is low, remove the expansion tank cap and add a 50/50 mixture of water and permanent ethylene-glycol antifreeze.

Important: Do not overfill.

3. Install the expansion-tank cap.

Bleeding the Fuel System

You must bleed the fuel system before starting the engine if any of the following situations have occurred:

- Initial start up of a new machine.
- Engine has ceased running due to lack of fuel.
- Maintenance has been performed upon fuel-system components (e.g., filter replaced).

▲ DANGER

Under certain conditions, diesel fuel and fuel vapors are highly flammable and explosive. A fire or explosion from fuel can burn you and others and can cause property damage.

- Use a funnel and fill the fuel tanks outdoors, in an open area, when the engine is off and is cold. Wipe up any fuel that spills.
- Do not fill the fuel tanks completely full. Add fuel to each fuel tank until the level is 6 to 13 mm (1/4 to 1/2 inch) below the bottom of the filler neck. This empty space in the tank allows the fuel to expand.
- Never smoke when handling fuel and stay away from an open flame or where fuel fumes may be ignited by a spark.
- Store fuel in a clean, safety-approved container and keep the cap in place.

1. Ensure that the fuel tanks are at least half full.
2. Open the hood and secure the hood prop.
3. Open the air-bleed screw on the fuel-injection pump (Figure 30).

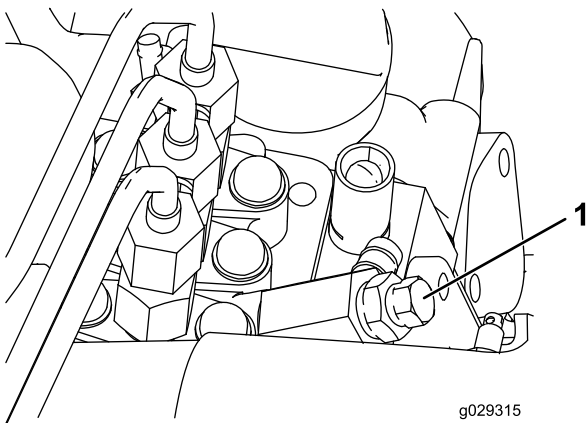

Figure 30

1. Air-bleed screw

4. Turn the key in the ignition switch to the ON position.

Note: The electric fuel pump will begin operation, thereby forcing air out around the air-bleed screw.

Leave the key in the ON position until a solid stream of fuel flows out around the screw.

5. Tighten the screw and turn the key to the OFF position.

Note: Normally, the engine should start after you follow the above bleeding procedure. However, if engine does not start, air may be trapped between injection pump and injectors; contact your Authorized Service Dealer.

Starting and Stopping the Engine

Starting the Engine

1. Ensure that the auxiliary-hydraulics lever and traction-control lever are in neutral.
2. Move the throttle lever midway between the SLOW and FAST positions.
3. Turn the ignition key to the ON position.
4. Wait for the glow-plug indicator light to stop blinking.
5. Turn the ignition key to the START position. When the engine starts, release the key.

Important: Do not engage the starter for more than 10 seconds at a time. If the engine fails to start, wait 30 seconds between attempts. Failure to follow these instructions can burn out the starter motor.

6. Move the throttle lever to desired setting.

Important: If you run the engine at high speeds when the hydraulic system is cold (i.e., when the ambient air temperature is near freezing or lower), hydraulic system damage could occur. When starting the engine in cold conditions, run the engine in the middle throttle position for 2 to 5 minutes before moving the throttle to the FAST position.

Note: If the outdoor temperature is below freezing, store the traction unit in a garage to keep it warmer and aid in starting.

Stopping the Engine

1. Move the throttle lever to the SLOW position.
2. Lower the loader arms to the ground.
3. Turn the ignition key off.

Note: If the engine has been working hard or is hot, let it idle for a minute before turning the ignition key off. This helps cool the engine before it is stopped. In an emergency, the engine may be stopped immediately.

Stopping the Machine

To stop the machine, release the traction control, move the throttle lever to the SLOW position, lower the loader arms to the ground, and shut off the engine. Set the parking brake and remove the key.

⚠ CAUTION

A child or untrained bystander could attempt to operate the traction unit and be injured.

Remove the key from the switch when leaving the traction unit, even if just for a few seconds.

Moving a Non-functioning Machine

Important: Do not tow or pull the traction unit without first opening the tow valves or the hydraulic system will be damaged.

1. Shut off the engine.
2. Open the hood and secure the hood prop.
3. Remove the side screens; refer to [Removing the Side Screens](#) (page 28).
4. Using a wrench, turn the tow valves on the hydraulic pumps twice counter-clockwise (Figure 31).

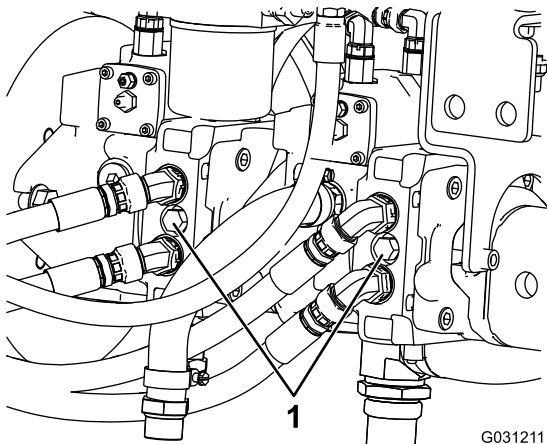
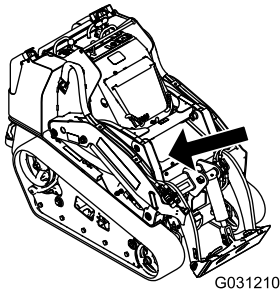

Figure 31

1. Tow valve

5. Tow the traction unit as required.
6. After repairing the machine, close the tow valves before operating it.

Using Attachments

Installing an Attachment

Important: Use only Toro-approved attachments. Attachments can change the stability and the operating characteristics of the traction unit. The warranty of the traction unit may be voided if used with unapproved attachments.

Important: Before installing the attachment, ensure that the mount plates are free of any dirt or debris and that the pins rotate freely. If the pins do not rotate freely, grease them.

1. Position the attachment on a level surface with enough space behind it to accommodate the traction unit.
2. Start the engine.
3. Tilt the attachment mount plate forward.
4. Position mount plate into the upper lip of the attachment receiver plate (Figure 32).

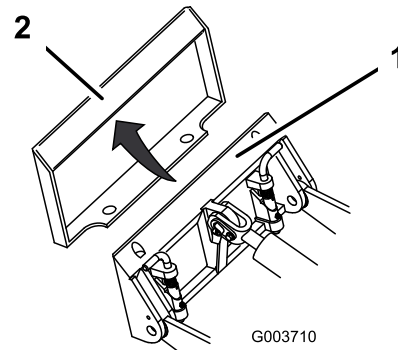

Figure 32

1. Mount plate
2. Receiver plate

5. Raise the loader arms while tilting back the mount plate at the same time.

Important: Raise the attachment enough to clear the ground and tilt the mount plate all the way back.

6. Shut off the engine.
7. Engage the quick-attach pins, ensuring that they are fully seated in the mount plate (Figure 33).

Important: If the pins do not rotate to the engaged position, the mount plate is not fully aligned with the holes in the attachment receiver plate. Check the receiver plate and clean it if necessary.

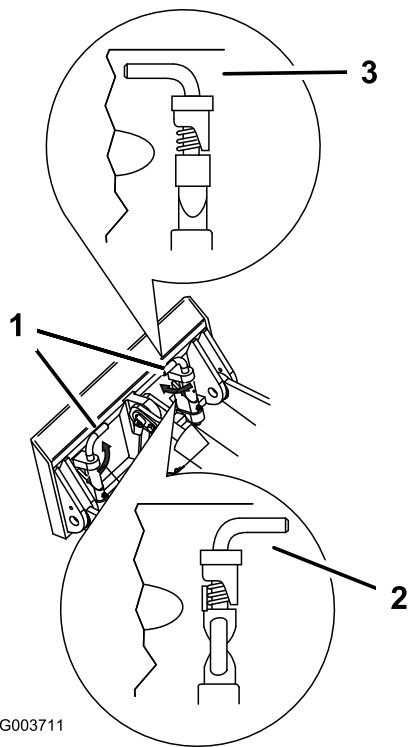

Figure 33

- | | |
|---------------------------------------|---------------------|
| 1. Quick-attach pins—engaged position | 3. Engaged position |
| 2. Disengaged position | |

⚠ WARNING

If you do not fully seat the quick-attach pins through the attachment mount plate, the attachment could fall off the traction unit, crushing you or bystanders.

Ensure that your quick-attach pins are fully seated in the attachment mount plate.

Connecting the Hydraulic Hoses

If the attachment requires hydraulics for operation, connect the hydraulic hoses as follows:

1. Shut off the engine.
2. Move the auxiliary-hydraulics lever forward, backward, and back to neutral to relieve pressure at the hydraulic couplers.
3. Remove the protective covers from the hydraulic couplers on the traction unit.
4. Ensure that all foreign matter is cleaned from the hydraulic connectors.
5. Push the attachment male connector into the female connector on the traction unit.

Note: When you connect the attachment male connector first, you relieve any pressure built up in the attachment.

⚠ WARNING

Hydraulic fluid escaping under pressure can penetrate skin and cause injury. Fluid injected into the skin must be surgically removed within a few hours by a doctor familiar with this form of injury or gangrene may result.

- Keep your body and hands away from pin hole leaks or nozzles that eject high pressure hydraulic fluid.
- Use cardboard or paper to find hydraulic leaks; never use your hands.

⚠ CAUTION

Hydraulic couplers, hydraulic lines/valves, and hydraulic fluid may be hot. If you contact hot components, you may be burned.

- Wear gloves when operating the hydraulic couplers.
- Allow the traction unit to cool before touching hydraulic components.
- Do not touch hydraulic fluid spills.

6. Push the attachment female connector into the male connector on the traction unit.
7. Confirm that the connection is secure by pulling on the hoses.

Removing an Attachment

1. Lower the attachment to the ground.
2. Shut off the engine.
3. Disengage the quick-attach pins by turning them to the outside.
4. If the attachment uses hydraulics, move the auxiliary-hydraulics lever forward, backward, and back to neutral to relieve pressure at the hydraulic couplers.
5. If the attachment uses hydraulics, slide the collar back on the hydraulic couplers and disconnect them.

Important: Connect the attachment hoses together to prevent hydraulic system contamination during storage.

6. Install the protective covers onto the hydraulic couplers on the traction unit.
7. Start the engine, tilt the mount plate forward, and back the traction unit away from the attachment.

Securing the Machine for Transport

Use a heavy-duty trailer or truck to transport the machine. Ensure that the trailer or truck has all the necessary brakes, lighting, and marking as required by law. Please carefully read all the safety instructions. Knowing this information could help you, your family, pets or bystanders avoid injury. Refer to your local ordinances for trailer and tie-down requirements.

⚠ WARNING

Driving on the street or roadway without turn signals, lights, reflective markings, or a slow-moving-vehicle emblem is dangerous and can lead to accidents causing personal injury.

Do not drive machine on a public street or roadway.

To transport the machine:

1. Lower the loader arms.
2. If using a trailer, connect it to the towing vehicle and connect the safety chains.
3. If applicable, connect the trailer brakes.
4. Carefully load the machine onto the trailer or truck.
5. Shut off the engine, remove the key, and set the brake.
6. Use the metal tie-down loops on the machine to securely fasten the machine to the trailer or truck with straps, chains, cable, or ropes ([Figure 34](#)).

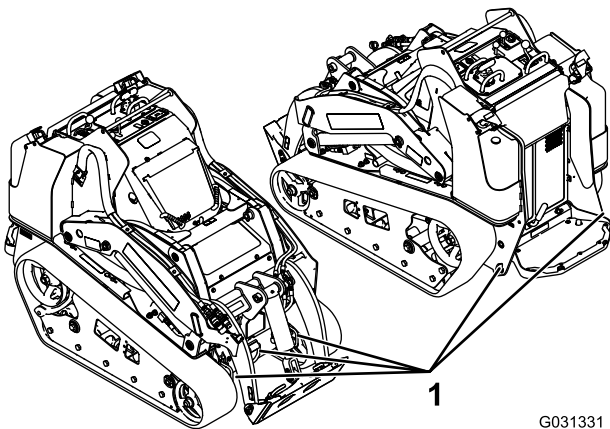

Figure 34

G031331

1. Tie-down loops

Lifting the Machine

You can lift the machine using the tie-down/lift loops as lift points indicated in [Figure 34](#).

Maintenance

Note: Determine the left and right sides of the machine from the normal operating position.

Recommended Maintenance Schedule(s)

Maintenance Service Interval	Maintenance Procedure
After the first 8 hours	<ul style="list-style-type: none"> • Replace the hydraulic filter.
After the first 50 hours	<ul style="list-style-type: none"> • Change the engine oil and filter. • Check and adjust the track tension.
Before each use or daily	<ul style="list-style-type: none"> • Check the engine oil level. • Check the level of coolant in the expansion tank. • Clean the screen, oil cooler, and front of the radiator (more often in dirty or dusty conditions). • Grease the machine. (Grease immediately after every washing.) • Check the air filter service indicator. • Drain water and other contaminants from the fuel filter/water separator. • Clean the tracks. • Check the tracks for excessive wear. • Clean the radiator. • Remove debris from the traction unit and side screens. • Check for loose fasteners.
Every 25 hours	<ul style="list-style-type: none"> • Check the hydraulic fluid level.
Every 50 hours	<ul style="list-style-type: none"> • Check the battery condition.
Every 100 hours	<ul style="list-style-type: none"> • Clean the air-cleaner element (more often in dusty or sandy conditions). • Change the engine oil. • Check and adjust the track tension. • Check the cooling system hoses. • Check the alternator/fan-belt tension (refer to the engine owner's manual for instructions). • Check the hydraulic lines for leaks, loose fittings, kinked lines, loose mounting supports, wear, weather, and chemical deterioration. • Check for dirt build-up in the chassis.
Every 200 hours	<ul style="list-style-type: none"> • Change the oil filter. • Replace the hydraulic filter.
Every 400 hours	<ul style="list-style-type: none"> • Check the fuel lines and connections for deterioration, damage, or loose connections. • Replace the fuel filter canister and in-line filter. • Change the hydraulic fluid.
Every 500 hours	<ul style="list-style-type: none"> • Replace the alternator/fan belt (refer to the engine owner's manual for instructions).
Every 1,500 hours	<ul style="list-style-type: none"> • Replace all moving hydraulic hoses.
Yearly	<ul style="list-style-type: none"> • Replace the air-cleaner element (more often in dusty or sandy conditions). • Change the engine coolant (Authorized Service Dealer only).
Yearly or before storage	<ul style="list-style-type: none"> • Check and adjust the track tension. • Touch up chipped paint.
Every 2 years	<ul style="list-style-type: none"> • Drain and clean the fuel tank (Authorized Service Dealer only).

Important: Refer to your engine owner's manual for additional maintenance procedures.

⚠ CAUTION

If you leave the key in the ignition switch, someone could accidentally start the engine and seriously injure you or other bystanders.

Remove the key from the ignition before you do any maintenance.

Premaintenance Procedures

Before opening any of the covers, shut the engine and remove the key. Allow the engine to cool before opening any covers

Using the Cylinder Lock

⚠ WARNING

The loader arms may lower when in the raised position, crushing anyone under them.

Install the cylinder lock before performing maintenance that requires raised loader arms.

Installing the Cylinder Lock

1. Remove the attachment.
2. Raise the loader arms to the fully raised position.
3. Shut off the engine.
4. Remove the 2 cotterless pins securing the cylinder lock to the posts on the sides of the machine.
5. Slide the cylinder locks over the lift-cylinder rod (Figure 35).

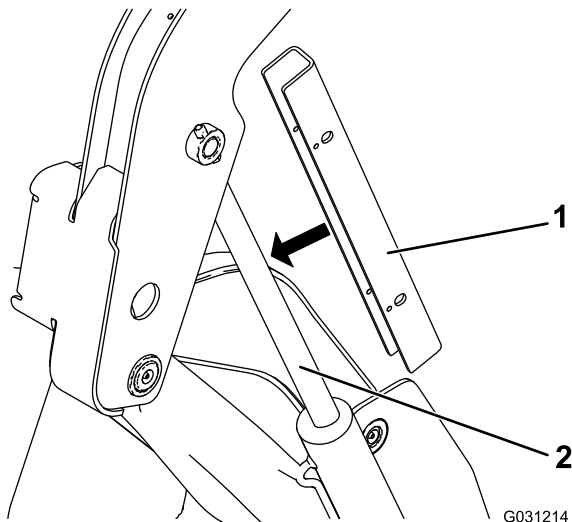

Figure 35

1. Cylinder lock
2. Cylinder rod

Removing/Storing the Cylinder Locks

Important: Remove the cylinder locks from the rod and fully secured in the storage position before operating the traction unit.

1. Start the engine.
2. Raise the loader arms to the fully raised position.
3. Shut off the engine.
4. Remove the cotterless pins securing the cylinder locks.
5. Place the cylinder locks on the posts on the sides of the machine and secure with the lynch pins.
6. Lower the loader arms.

Opening the Hood

1. Loosen the hood-locking screw (Figure 36)

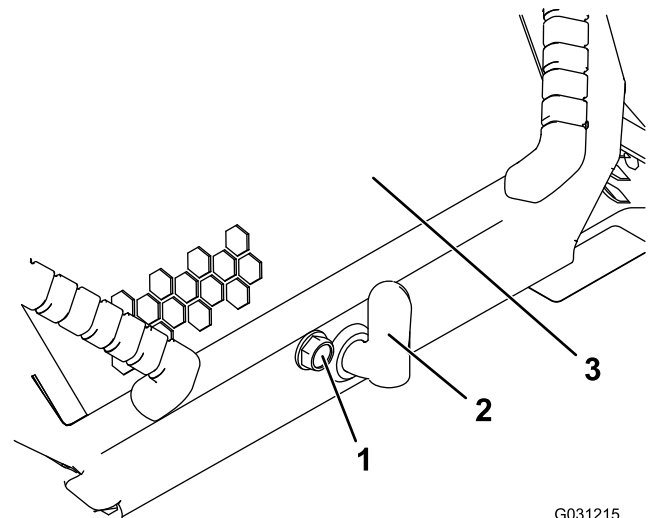

Figure 36

1. Hood-locking screw
2. Hood-latch lever
3. Hood

2. Turn the hood latch clockwise (Figure 36).
3. Lift up on the handles and swing the hood up (Figure 36).
4. Secure the hood prop.

6. Repeat for the other side of the machine.
7. **Slowly** lower the loader arms until the cylinder lock contacts the cylinder body and rod end.

Closing the Hood

1. Lift up on the tab securing the prop-rod (Figure 37)

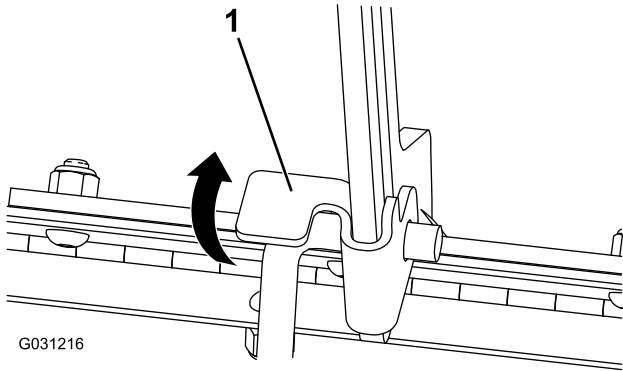

Figure 37

1. Prop-rod tab
-
2. Lower the hood and secure it by pushing down on the front of the hood until it locks in place.
 3. Tighten the hood-locking screw to secure the latch (Figure 36).

Opening the Rear-Access Cover

1. Remove the fastener (Figure 38).

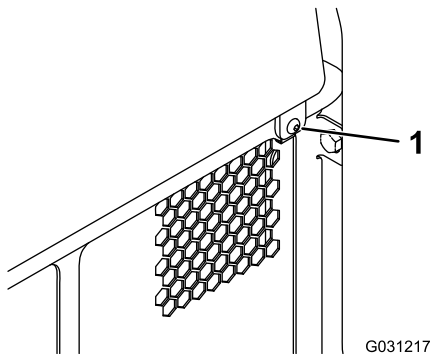

Figure 38

1. Fastener
-
2. Lift the rear-access cover up to access the internal components (Figure 38).
 3. Lower the rear-access cover and install the fastener to close the cover.

Removing the Front Screen

1. Open the hood and secure the hood prop.
2. Loosen the 2 top bolts and 2 front bolts.

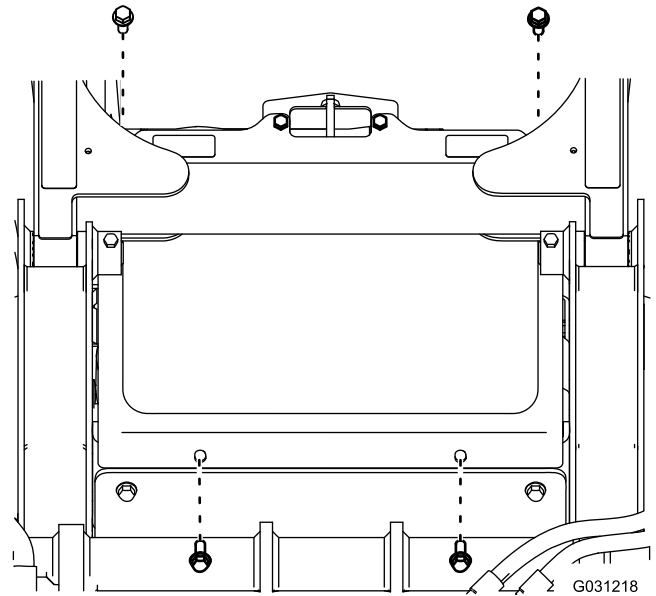

Figure 39

1. Bolt
-
3. Remove the screen.

Removing the Side Screens

1. Open the hood and secure the hood prop.
2. Slide the side screens (Figure 40) up and out of the slots in the front screen and frame.

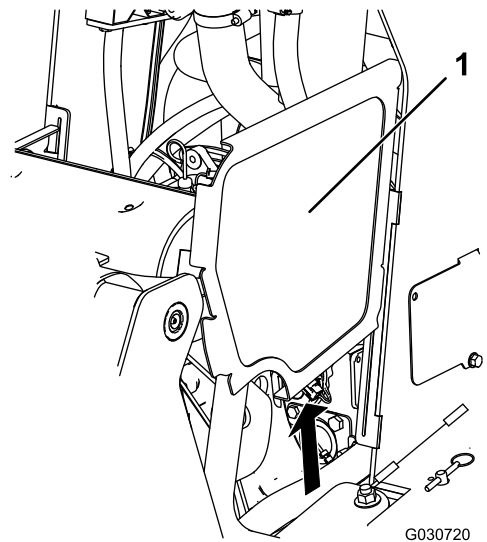

Figure 40

Loader arms not shown for clarity

1. Side screen
-

Lubrication

Greasing the Machine

Service Interval: Before each use or daily (Grease immediately after every washing.)

Grease Type: General-purpose grease.

1. Lower the loader arms and shut off the engine. Remove the key.
2. Clean the grease fittings with a rag.
3. Connect a grease gun to each fitting (Figure 41, Figure 42, and Figure 43).

Note: Raise the loader arms before greasing the fittings in Figure 43.

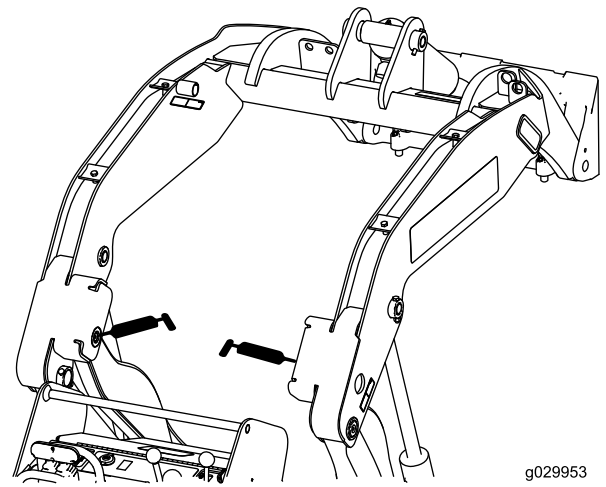

g029953

Figure 43

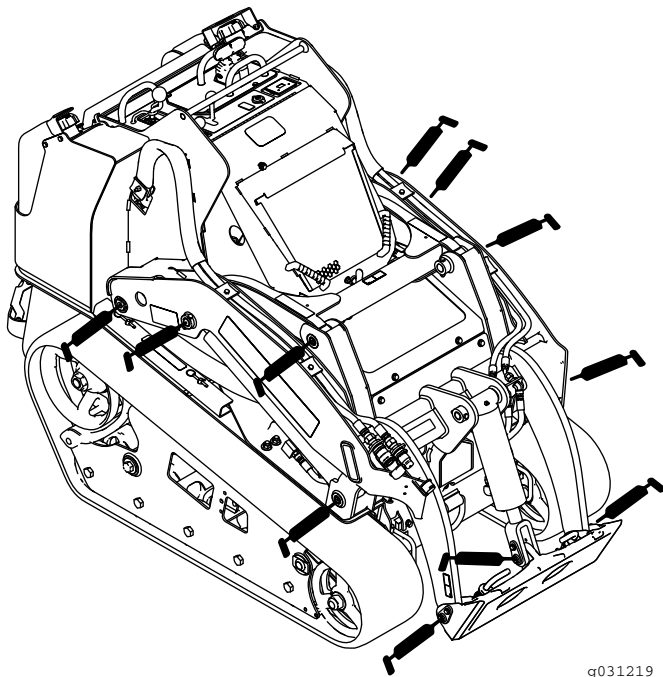

g031219

Figure 41

4. Pump grease into the fittings until grease begins to ooze out of the bearings (approximately 3 pumps).
5. Wipe up any excess grease.

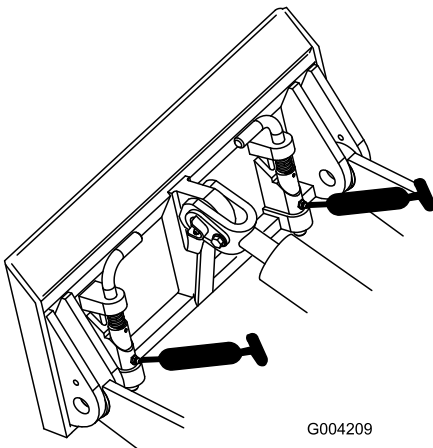

G004209

Figure 42

Engine Maintenance

Servicing the Air Cleaner

Service Interval: Before each use or daily—Check the air filter service indicator.

Every 100 hours—Clean the air-cleaner element (more often in dusty or sandy conditions).

Yearly—Replace the air-cleaner element (more often in dusty or sandy conditions).

Servicing the Air Cleaner Cover and Body

Important: Service the air-cleaner filter only when the service indicator shows red (Figure 44). Changing the air filter before it is necessary only increases the chance of dirt entering the engine when the filter is removed.

1. Lower the loader arms, shut off the engine, and remove the key.
2. Open the hood and secure the hood prop.
3. Check the air-cleaner body for damage that could cause an air leak. Check the whole intake system for leaks, damage, or loose hose clamps. Replace or repair and damaged components.
4. Release the latches on the air cleaner and pull the air-cleaner cover off the air-cleaner body (Figure 44).

Important: Do not remove the air filter.

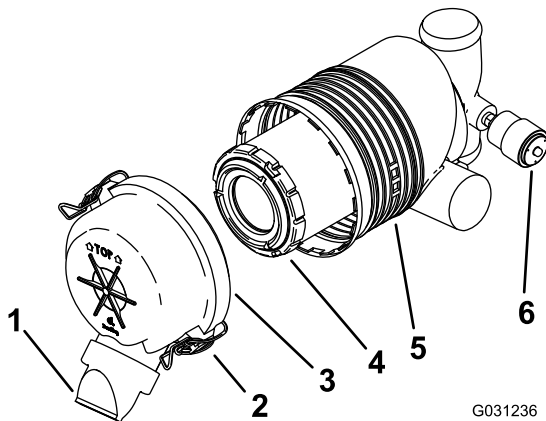

Figure 44

- | | |
|----------------------|----------------------------------|
| 1. Dust cap | 4. Primary filter |
| 2. Latch | 5. Air-filter body |
| 3. Air-cleaner cover | 6. Air-filter service indicator. |

- If the service indicator is clear, clean any debris from cover and install cover.
Ensure that the cover is seated correctly and seals with the air-cleaner body.
 - If the service indicator is red, replace the air filter as described in [Replacing the Filter \(page 30\)](#).
8. Install the air-cleaner cover.

Note: Ensure that the dust cap is oriented downward.

Replacing the Filter

Important: To prevent engine damage, always operate the engine with the air filter and cover installed.

1. Gently slide the filter out of the air-cleaner body (Figure 44).

Note: Avoid knocking the filter into the side of the body.

Important: Do not attempt to clean the filter.

2. Inspect the new filter for damage by looking into the filter while shining a bright light on the outside of the filter.

Note: Holes in the filter appear as bright spots.

3. Inspect the element for tears, an oily film, or damage to the rubber seal. If the filter is damaged do not use it.
4. Carefully install the filter (Figure 44).

Note: Ensure that the filter is fully seated by pushing on the outer rim of the filter while installing it.

Important: Do not press on the soft inside area of the filter.

5. Install the air-cleaner cover with the side indicated as TOP facing up and secure the latches (Figure 44).
6. Close the hood.

5. Squeeze the dust cap sides to open it and knock the dust out.
6. Clean the inside of the air-cleaner cover with compressed air that is under 205 kPa (30 psi).
7. Check the air-filter service indicator.

Servicing the Engine Oil

Service Interval: After the first 50 hours—Change the engine oil and filter.

Every 100 hours—Change the engine oil.

Every 200 hours—Change the oil filter.

Note: Change the oil and oil filter more frequently when operating conditions are extremely dusty or sandy.

Oil Type: Detergent diesel engine oil (API service CH-4 or higher)

Crankcase Capacity: with filter 5.7 L (1.5 US gallons)

Viscosity: See the table below.

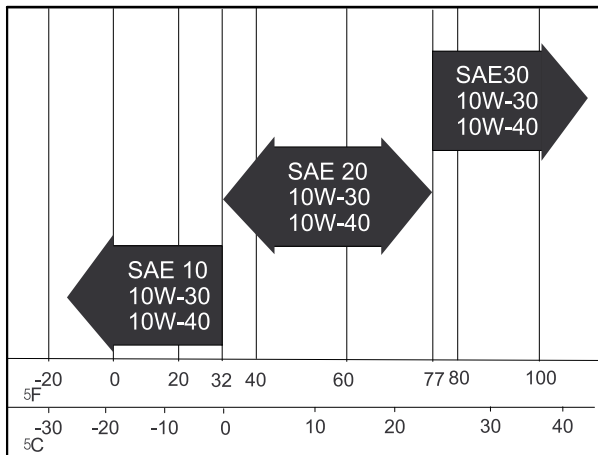

Figure 45

G001061

Changing the Engine Oil

1. Start the engine and let it run for 5 minutes.

Note: This warms the oil so that it drains better.
2. Park the traction unit so that the drain side is slightly lower than the opposite side to ensure that the oil drains completely.
3. Lower the loader arms, set the parking brake, shut off the engine, and remove the key.
4. Drain the oil beneath the platform (Figure 46).

⚠ CAUTION

Components will be hot if the traction unit has been running. If you touch hot components you may be burned.

Allow the traction unit to cool before performing maintenance or touching components under the hood.

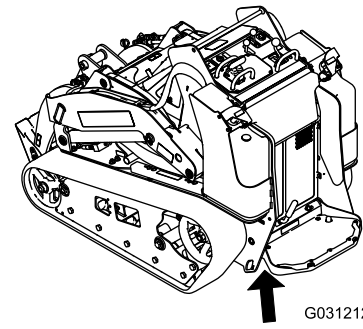

G031212

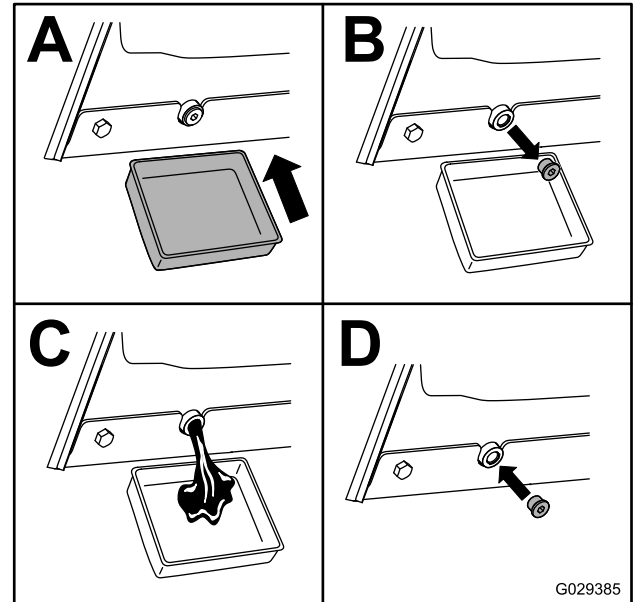

G029385

Figure 46

5. Remove the oil-fill cap and slowly pour approximately 80% of the specified amount of oil in through the valve cover.
6. Check the oil level; refer to [Checking the Engine-Oil Level \(page 20\)](#).
7. Slowly add additional oil to bring the level to the upper hole on the dipstick.
8. Replace the fill cap.

Changing the Oil Filter

1. Open the hood and secure the hood prop.
2. Drain the oil from the engine; refer to [Changing the Engine Oil \(page 31\)](#).
3. Place a shallow pan or rag under the filter to catch oil.
4. Change the oil filter ([Figure 47](#)).

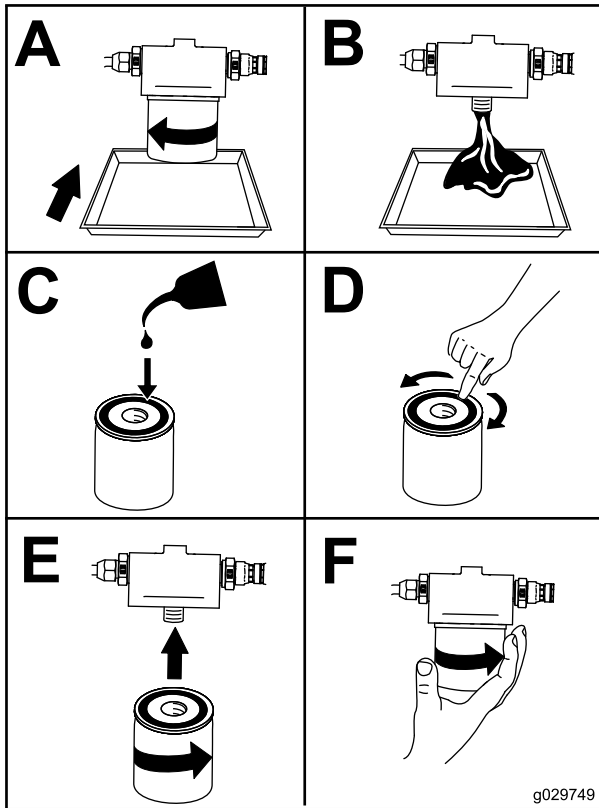

Figure 47

5. Fill the crankcase with the proper type of new oil; refer to [Changing the Engine Oil \(page 31\)](#).

Fuel System Maintenance

⚠ DANGER

Under certain conditions, diesel fuel and fuel vapors are highly flammable and explosive. A fire or explosion from fuel can burn you and others and can cause property damage.

- Use a funnel and fill the fuel tanks outdoors, in an open area, when the engine is off and is cold. Wipe up any fuel that spills.
- Do not fill the fuel tanks completely full. Add fuel to each fuel tank until the level is 6 to 13 mm (1/4 to 1/2 inches) below the bottom of the filler neck. This empty space in the tank allows the fuel to expand.
- Never smoke when handling fuel and stay away from an open flame or where fuel fumes may be ignited by a spark.
- Store fuel in a clean, safety-approved container and keep the cap in place.

Checking the Fuel Lines and Connections

Service Interval: Every 400 hours/Yearly (whichever comes first)

Inspect the fuel lines and connections for deterioration, damage, or loose connections. Tighten any loose connections and contact your Authorized Service Dealer for assistance in fixing damaged fuel lines.

Draining the Fuel Filter/Water Separator

Service Interval: Before each use or daily

1. Locate the fuel filter on the rear side of the engine (Figure 48) and place a clean container under it.

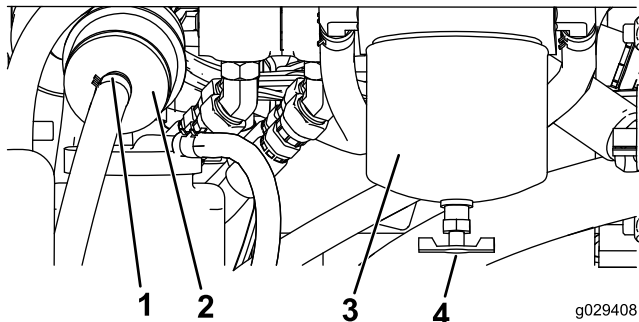

Figure 48

- | | |
|-------------------|---|
| 1. Hose clamp | 3. Fuel-filter canister/water separator |
| 2. In-line filter | 4. Drain valve |

2. Loosen the drain valve on the bottom of the filter canister and allow the water to drain.
3. When finished, tighten the drain valve.

Replacing the Fuel Filter Canister and In-Line Filter

Service Interval: Every 400 hours

1. Locate the fuel filters on the right side of the engine (Figure 48) and place a clean container under it.
2. Clean the area where the filter canister mounts (Figure 48).
3. Remove the filter canister and clean the mounting surface (Figure 48).
4. Lubricate the gasket on the new filter canister with clean oil.
5. Install the filter canister by hand until the gasket contacts the mounting surface, then rotate it an additional 1/2 turn (Figure 48).
6. Locate the in-line filter behind the fuel filter canister (Figure 48) and note the direction of flow arrow on the side of the in-line filter.
7. Open the clamps on each end of the in-line filter and slide the hoses off it (Figure 48). Discard the filter.
8. Slide the hoses over the end of a new filter (Figure 48), ensuring that the arrow on the filter is pointing in the same direction as the one on the old filter.
9. Secure the hoses with the hose clamps.

Draining the Fuel Tanks

Service Interval: Every 2 years

Have an Authorized Service Dealer drain and clean the fuel tanks.

Electrical System Maintenance

Servicing the Battery

Service Interval: Every 50 hours

⚠ WARNING

CALIFORNIA Proposition 65 Warning

This product contains a chemical or chemicals known to the State of California to cause cancer, birth defects, or reproductive harm.

Important: Before welding on the machine, disconnect the negative cable from the battery.

Charging and Connecting the Battery

⚠ DANGER

Battery electrolyte contains sulfuric acid, which is a deadly poison and causes severe burns.

- Do not drink electrolyte and avoid contact with skin, eyes or clothing. Wear safety glasses to shield your eyes and rubber gloves to protect your hands.
- Fill the battery where clean water is always available for flushing the skin.

⚠ WARNING

Battery terminals or metal tools could short against metal components causing sparks. Sparks can cause the battery gasses to explode, resulting in personal injury.

- When removing or installing the battery, do not allow the battery terminals to touch any metal parts of the machine.
- Do not allow metal tools to short between the battery terminals and metal parts of the machine.

⚠ WARNING

Incorrect battery cable routing could damage the machine and cables causing sparks. Sparks can cause the battery gasses to explode, resulting in personal injury.

- Always disconnect the negative (black) battery cable before disconnecting the positive (red) cable.
 - Always connect the positive (red) battery cable before connecting the negative (black) cable.
1. Remove the front screen; refer to [Removing the Front Screen](#) (page 28).
 2. Connect a 3 to 4 A battery charger to the battery posts.
 3. Charge the battery at a rate of 3 to 4 A for 4 to 8 hours.
 4. When the battery is charged, disconnect the charger from the electrical outlet and battery posts.

⚠ WARNING

Charging the battery produces gasses that can explode.

Never smoke near the battery and keep sparks and flames away from battery.

5. Install the positive cable (red) to the positive (+) terminal and the negative cable (black) to the negative (-) terminal of the battery ([Figure 49](#)).

Important: Secure cables to posts with capscrews and nuts. Make sure that the positive (+) terminal is all of the way onto the post and the cable is positioned snug to the battery. The cable must not contact the battery cover. Slide the rubber boot over the positive terminal to prevent a possible short from occurring.

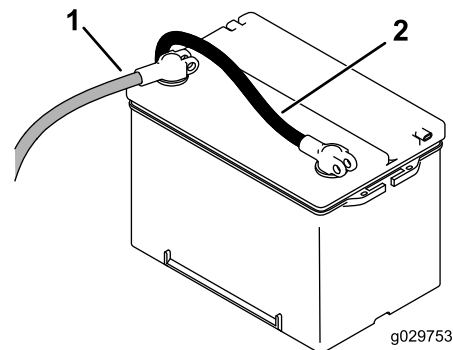

Figure 49

1. Positive battery cable
2. Negative battery cable

6. Coat both battery connections with Grafo 112X (skin-over) grease (Toro Part Number 505-47), petroleum jelly, or light grease to prevent corrosion. Slide the rubber boot over the positive terminal.
7. Install the front screen.

Cleaning the Battery

Note: Keep the terminals and the entire battery case clean, because a dirty battery discharges slowly.

1. Remove the front screen; refer to [Removing the Front Screen](#) (page 28).
2. Remove the battery from the machine.
3. Wash the entire case with a solution of baking soda and water.
4. Rinse the battery with clear water.
5. Coat the battery posts and cable connectors with Grafo 112X (skin-over) grease (Toro Part Number 505-47) or petroleum jelly to prevent corrosion.
6. Install the front screen.

Servicing the Fuses

The electrical system is protected by fuses. It requires no maintenance; however, if a fuse blows, check the component/circuit for a malfunction or a short. [Figure 50](#) illustrates the fuse block and identifies the fuse positions.

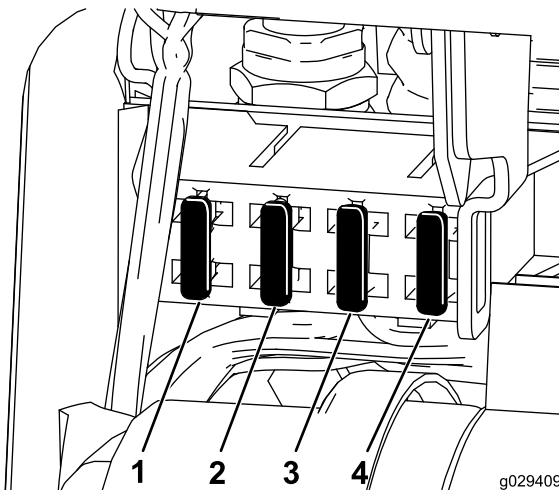

Figure 50

- | | |
|--------------|---------------|
| 1. Fuse—20 A | 3. Fuse—10 A |
| 2. Fuse—15 A | 4. Fuse—7.5 A |

Note: If the traction unit does not start, either the main circuit or the control panel/relay fuse could be blown.

Drive System Maintenance

Servicing the Tracks

Service Interval: After the first 50 hours—Check and adjust the track tension.

Before each use or daily—Clean the tracks.

Before each use or daily—Check the tracks for excessive wear.

Every 100 hours—Check and adjust the track tension.

Cleaning the Tracks

1. With a bucket on the loader arms, lower the bucket to the ground so that the front of the traction unit lifts off the ground a few inches.
2. Shut off the engine and remove the key.
3. Using a water hose or pressure washer, remove dirt from each track system.

Important: Ensure that you use high-pressure water to wash only the track area. Do not use a high-pressure washer to clean the rest of the traction unit. Do not use high pressure water between the drive sprocket and the traction unit or you may damage the motor seals. High-pressure washing can damage the electrical system and hydraulic valves or deplete grease.

Important: Ensure that you fully clean the road wheels, the front wheel, and the drive sprocket ([Figure 51](#)). The road wheels should rotate freely when clean.

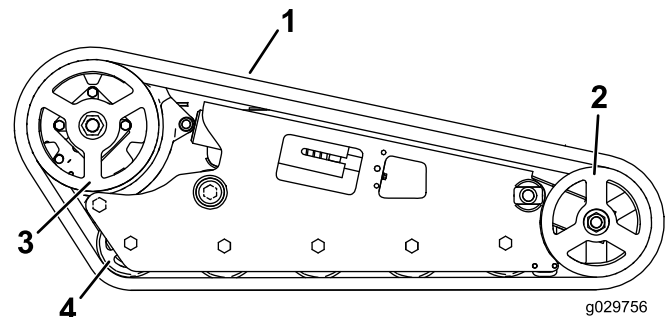

Figure 51

- | | |
|----------------|-------------------|
| 1. Track | 3. Drive sprocket |
| 2. Front wheel | 4. Road wheel |

Adjusting the Track Tension

The tension nut should be 0.64 cm (1/4 inch) away from the tangent of the tension tube slot (Figure 52). If it is not, adjust the track tension using the following procedure:

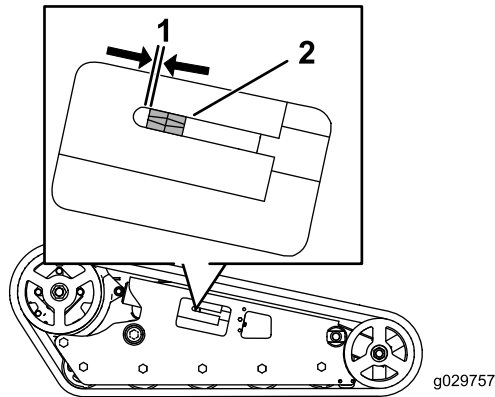

Figure 52

1. 0.64 cm (1/4 inch)
2. Tension nut

1. Lower the loader arms, shut off the engine, and remove the key.
2. Lift/support the side of the unit to be worked on so that the track is off the ground.
3. Remove the locking bolt and nut (Figure 53).

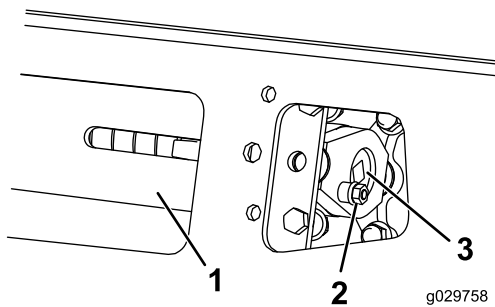

Figure 53

1. Tension tube
2. Locking bolt
3. Tensioning screw

4. Using a 1/2 inch drive socket, turn the tensioning screw counter-clockwise until the distance between the tension nut and the back of the tension tube is 0.64 cm (1/4 inch), as shown in Figure 52)
5. Align the closest notch in the tension screw to the locking-bolt hole and secure the screw with the locking bolt and nut (Figure 53).
6. Lower the traction unit to the ground.

Replacing the Tracks

Model 22327

Replace the tracks when they are badly worn.

1. Lower the loader arms, shut off the engine, and remove the key.
2. Lift/support the side of the unit to be worked on so that the track is 3 to 4 inches (7.6 to 10 cm) off the ground.
3. Using a 1/2-inch drive socket, release the drive tension by turning the tensioning screw clockwise (Figure 53 and Figure 54).

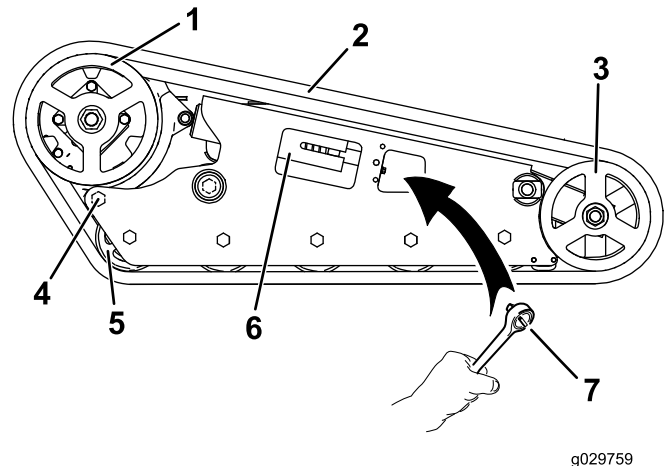

Figure 54

- | | |
|-------------------|----------------------|
| 1. Drive sprocket | 5. Road wheel |
| 2. Track | 6. Fork tube |
| 3. Front wheel | 7. Socket (1/2 inch) |
| 4. Rear bolt | |

4. Loosen the rear bolt, near the drive wheel (Figure 54).

Note: This enables the drive wheel to pivot forward and release the tension of the track. If it does not pivot, turn on the engine and briefly move the traction control forward.
5. Remove the track at the top of the front wheel, peeling it off the wheel while rotating the track forwards.
6. When the track is off the front wheel, remove it from the drive sprocket and road wheels (Figure 54).
7. Beginning at the drive sprocket, coil the new track around the sprocket, ensuring that the lugs on the track fit between the spacers on the sprocket (Figure 54).
8. Push the track under and between the road wheels (Figure 54).
9. Starting at the bottom of the front wheel, install the track around the wheel by rotating the track rearward while pushing the lugs into the wheel.
10. Turn the tensioning screw counter-clockwise until the distance between the tension nut and the back of the fork tube (Figure 52) is 0.64 cm (1/4 inch).

11. Align the closest notch in the tension screw to the locking bolt hole and secure the screw with the locking bolt and nut.
12. Torque the rear bolt 163 to 217 N·m (120 to 160 ft-lb).
13. Lower the traction unit to the ground.
14. Repeat steps 2 through 13 to replace the other track.

11. Align the closest notch in the tension screw to the locking bolt hole and secure the screw with the locking bolt and nut.
12. Torque the rear bolt 163 to 217 N·m (120 to 160 ft-lb).
13. Lower the traction unit to the ground.
14. Repeat steps 1 through 13 to replace the other track.

Replacing the Tracks

Model 22328

1. Follow steps 1 through 4 of [Replacing the Tracks \(page 36\)](#) of model 22327.
2. Remove the nut securing the outer front wheel and remove the wheel ([Figure 55](#)).

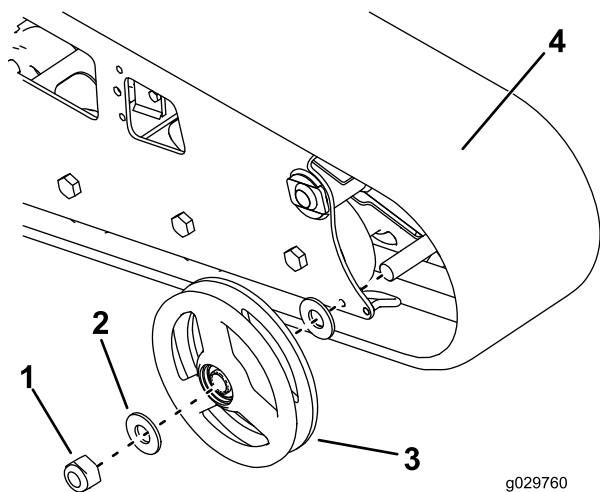

Figure 55

- | | |
|-----------|----------------------|
| 1. Nut | 3. Outer front wheel |
| 2. Washer | 4. Track |

3. Remove the track ([Figure 55](#)).
 4. Pull the 2 large washers out of the outer wheels, 1 on each side of each wheel ([Figure 55](#)).
 5. Clean the old grease and dirt out of the area between where the washers were installed and the bearings inside the wheels, then fill this area on each side of each wheel with grease.
 6. Install the large washers on the wheels over the grease.
 7. Install the new track. ([Figure 55](#)).
- Note:** Ensure that the lugs in the track fit between the spacers in the middle of the drive sprocket.
8. Install the outer front wheel and secure it with the nut removed previously ([Figure 55](#)).
 9. Torque the nut to 300 ft-lb (407 N·m).
 10. Turn the tensioning screw counter-clockwise until the distance between the tension nut and the tangent of the tension-tube slot ([Figure 52](#)) is 0.65 cm (1/4 inch).

Cooling System Maintenance

Servicing the Cooling System

Service Interval: Before each use or daily—Clean the radiator.

Every 100 hours—Check the cooling system hoses.

Yearly—Change the engine coolant (Authorized Service Dealer only).

▲ DANGER

If the engine has been running, the pressurized, hot coolant can escape and cause severe burns.

- Do not remove the radiator cap when the engine is hot. Always allow the engine to cool at least 15 minutes or until the radiator cap is cool enough to touch without burning your hand before removing the radiator cap.
- Do not touch radiator and surrounding parts that are hot.
- Use a rag when opening the radiator cap, and open the cap slowly to allow steam to escape.

▲ DANGER

Rotating shaft and fan can cause personal injury.

- Do not operate the machine without the covers in place.
- Keep fingers, hands and clothing clear of rotating fan and drive shaft.
- Shut off the engine and remove the ignition key before performing maintenance.

▲ CAUTION

Swallowing engine coolant can cause poisoning.

- Do not swallow engine coolant.
- Keep out of reach from children and pets.

Cleaning the Radiator Screen

Before each use, check and clean the radiator screen, located in front of the operator platform. Remove any build-up of grass, dirt or other debris from the radiator screen with compressed air.

Changing the Engine Coolant

Have an Authorized Service Dealer change the engine coolant yearly.

If you need to add engine coolant, refer to [Checking the Engine Coolant \(page 21\)](#).

Belt Maintenance

Checking the Alternator/Fan Belt Tension

Service Interval: Every 100 hours—Check the alternator/fan-belt tension (refer to the engine owner's manual for instructions).

Every 500 hours—Replace the alternator/fan belt (refer to the engine owner's manual for instructions).

Controls System Maintenance

The factory adjusts the controls before shipping the traction unit. However, after many hours of use, you may need to adjust the traction-control alignment, the neutral position of the traction control, and the tracking of the traction control in the full forward position.

Contact your Authorized Service Distributor to adjust the controls of your machine.

Hydraulic System Maintenance

Replacing the Hydraulic Filter

Service Interval: After the first 8 hours

Every 200 hours

Important: Do not substitute an automotive oil filter or severe hydraulic system damage may result.

1. Position traction unit on a level surface.
2. Lower the loader arms, shut off the engine, and remove the key.
3. Open the hood and secure the hood prop.
4. Place a drain pan under the filter and replace the filter (Figure 56).

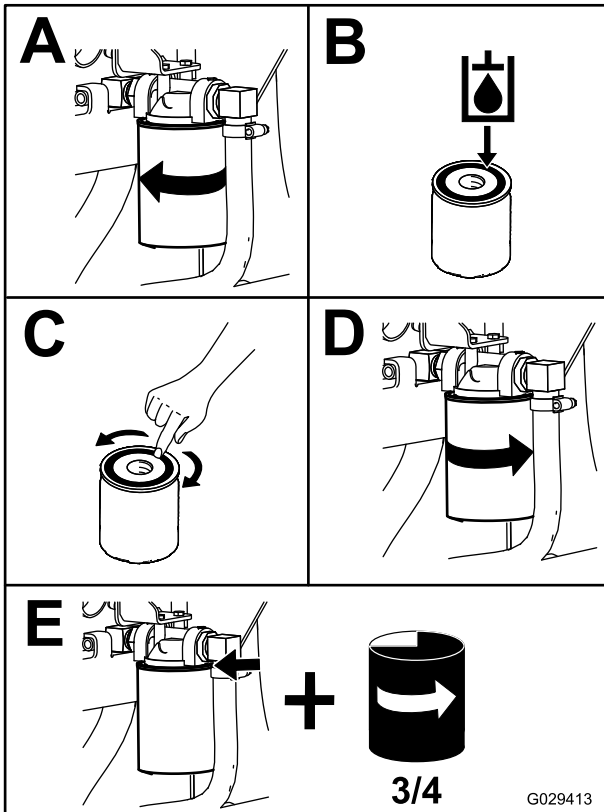

Figure 56

5. Clean up any spilled fluid.
6. Start the engine and let it run for about 2 minutes to purge air from the system.
7. Shut off the engine and check for leaks.

⚠ WARNING

Hydraulic fluid escaping under pressure can penetrate skin and cause injury. Fluid injected into the skin must be surgically removed within a few hours by a doctor familiar with this form of injury or gangrene may result.

- Keep your body and hands away from pin hole leaks or nozzles that eject high pressure hydraulic fluid.
- Use cardboard or paper to find hydraulic leaks, never use your hands.

8. Check the fluid level in the hydraulic tank; refer to [Checking the Hydraulic Fluid Level \(page 20\)](#) and add fluid to raise the level to mark on dipstick.

Important: Do not over fill the tank.

9. Close the rear-access cover.

Changing the Hydraulic Fluid

Service Interval: Every 400 hours/Yearly (whichever comes first)

Hydraulic Fluid Specification:

Use only one of the following fluids in the hydraulic system:

- **Toro Premium Transmission/Hydraulic Tractor Fluid** (refer to your Authorized Toro Dealer for more information)
- **Toro Premium All Season Hydraulic Fluid** (refer to your Authorized Toro Dealer for more information)
- If either of the above Toro fluids are not available, you may use another **Universal Tractor Hydraulic Fluid (UTHF)**, but they must be only **conventional, petroleum-based** products. The specifications must fall within the listed range for all of the following material properties and the fluid should meet the listed industry standards. Check with your oil supplier to determine if the oil meets these specifications.

Note: Toro will not assume responsibility for damage caused by improper substitutions, so use only products from reputable manufacturers who will stand behind their recommendations.

Material Properties	
Viscosity, ASTM D445	cSt at 40°C: 55 to 62
	cSt at 100°C: 9.1 to 9.8
Viscosity index, ASTM D2270	140 to 152
Pour Point, ASTM D97	-37 to -43°C (-35 to -46°F)
Industry Standards	
API GL-4, AGCO Powerfluid 821 XL, Ford New Holland FNHA-2-C-201.00, Kubota UDT, John Deere J20C, Vickers 35VQ25 and Volvo WB-101/BM.	

Note: Many hydraulic fluids are almost colorless, making it difficult to spot leaks. A red dye additive for the hydraulic system oil is available in 20 ml (2/3 oz) bottles. One bottle is sufficient for 15-22 L (4-6 US gallons) of hydraulic oil. Order part no. 44-2500 from your Authorized Toro Dealer.

1. Position the traction unit on a level surface, shut off the engine, remove the key, and allow the traction unit to cool completely.
2. Open the hood and secure the hood prop.
3. Remove the right side screen; refer to [Removing the Side Screens](#) (page 28).
4. Remove the hydraulic-tank cap and dipstick ([Figure 57](#)).

Note: Raising the loader arms may improve your access to the hydraulic-tank cap. Install the cylinder lock if you raise the arms; refer to [Installing the Cylinder Lock](#) (page 27).

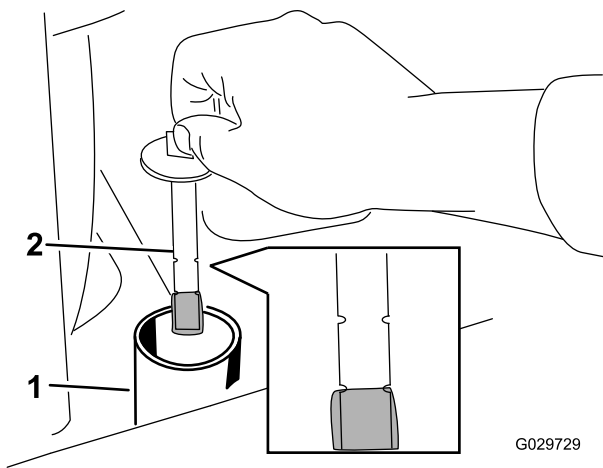

Figure 57

1. Filler neck
2. Dip stick

5. Place a large drain pan (capable of holding 57 or 15 US gallons) under the drain plug on the front of the traction unit ([Figure 58](#)).

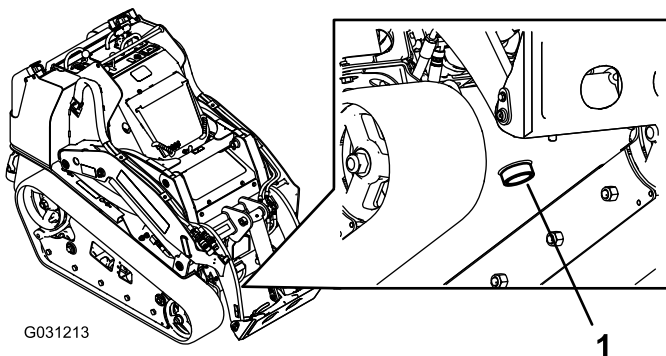

Figure 58

1. Drain plug

6. Remove the drain plug and allow the oil to drain into the pan ([Figure 58](#)).

7. When the oil is finished draining, install and tighten the drain plug.

Note: Dispose of the used oil at a certified recycling center.

8. Fill the hydraulic tank with approximately 38 L (10 US gallons) of hydraulic fluid as specified previously in this section.
9. Start the engine and let it run for a few minutes.
10. Shut off the engine.
11. Check the hydraulic fluid level and top it off if necessary; refer to [Checking the Hydraulic Fluid Level](#) (page 20).
12. Close the hood.

Checking the Hydraulic Lines

Service Interval: Every 100 hours—Check the hydraulic lines for leaks, loose fittings, kinked lines, loose mounting supports, wear, weather, and chemical deterioration. (Make necessary repairs before operating.)

Every 1,500 hours/Every 2 years (whichever comes first)—Replace all moving hydraulic hoses.

⚠ WARNING

Hydraulic fluid escaping under pressure can penetrate skin and cause injury. Fluid injected into the skin must be surgically removed within a few hours by a doctor familiar with this form of injury or gangrene may result.

- Keep your body and hands away from pin hole leaks or nozzles that eject high pressure hydraulic fluid.
- Use cardboard or paper to find hydraulic leaks, never use your hands.

Cleaning

Removing Debris from the Traction Unit

Service Interval: Before each use or daily

Important: Operating the engine with blocked screens and/or cooling shrouds removed, will result in engine damage from overheating.

1. Park the traction unit on a level surface, lower the loader arms, and shut off the engine.
2. Remove the key and allow the engine to cool.
3. Open the hood and secure the hood prop.
4. Clean any debris from the front and side screens.
5. Wipe away debris from the air cleaner.
6. Clean any debris build-up on the engine and in the oil cooler fins with a brush or blower.

Important: It is preferable to blow dirt out, rather than washing it out. If you use water, keep it away from electrical items and hydraulic valves. Do not use a high-pressure washer. High-pressure washing can damage the electrical system and hydraulic valves or deplete grease.

7. Clean debris from the hood opening, muffler, heat shields, and radiator screen.
8. Close the hood.

Cleaning the Chassis

Service Interval: Every 100 hours—Check for dirt build-up in the chassis.

Over time, the chassis under the engine collects dirt and debris that must be removed. Using a flashlight, open the hood and inspect the area under the engine on a regular basis. When the debris is 2.5 to 5.1 cm (1 to 2 inches) deep, clean the chassis.

1. Lower the loader arms, shut off the engine, and remove the key.
2. Raise the front of the machine so that the machine is angled backward.
3. Remove the 2 bolts securing the bottom plate and remove the bottom plate (Figure 59).

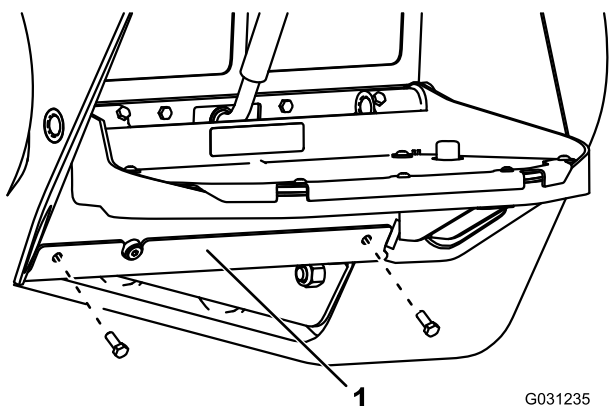

1
Figure 59

1. Bottom plate

-
4. Remove the front screen; refer to [Removing the Front Screen \(page 28\)](#).
 5. Spray water into the chassis to clean out the dirt and debris.

Note: The water will drain at the back of the machine.

Important: Do not spray water into the engine.

6. Grease the machine; refer to [Greasing the Machine \(page 29\)](#).
7. Install the bottom plate (Figure 59).
8. Install the front screen.
9. Lower the machine.

Storage

1. Lower the loader arms, shut off the engine, and remove the key.
2. Remove dirt and grime from the entire traction unit.

Important: You can wash the traction unit with mild detergent and water. Do not pressure wash the traction unit. Avoid excessive use of water, especially near the control panel, engine, hydraulic pumps, and motors.

3. Service the air cleaner; refer to [Servicing the Air Cleaner \(page 30\)](#).
4. Grease the traction unit; refer to [Greasing the Machine \(page 29\)](#).
5. Change the crankcase oil; refer to [Changing the Engine Oil \(page 31\)](#).
6. Charge the battery; refer to [Charging and Connecting the Battery \(page 34\)](#).
7. Check and adjust the track tension; refer to [Adjusting the Track Tension \(page 36\)](#).
8. Check and tighten all bolts, nuts, and screws. Repair or replace any part that is damaged.
9. Paint all scratched or bare metal surfaces. Paint is available from your Authorized Service Dealer.
10. Store the traction unit in a clean, dry garage or storage area. Remove the key from the ignition switch and keep it in a memorable place.
11. Cover the traction unit to protect it and keep it clean.

Troubleshooting

Problem	Possible Cause	Corrective Action
The starter does not crank.	<ol style="list-style-type: none"> 1. The electrical connections are corroded or loose. 2. A fuse is blown or loose. 3. The battery is discharged. 4. The relay or switch is damaged. 5. A starter or starter solenoid is damaged. 6. The internal engine components have seized. 7. The safety interlock is engaged. 	<ol style="list-style-type: none"> 1. Check the electrical connections for good contact. 2. Correct or replace the fuse. 3. Charge the battery or replace it. 4. Contact your Authorized Service Dealer. 5. Contact your Authorized Service Dealer. 6. Contact your Authorized Service Dealer. 7. Check the neutral setting on the traction and auxiliary controls.
The engine cranks, but does not start.	<ol style="list-style-type: none"> 1. An incorrect starting procedure was used. 2. The fuel tank is empty. 3. The fuel shutoff valve is closed. 4. Dirt, water, stale fuel, or incorrect fuel is in the fuel system. 5. The fuel line is clogged. 6. There is air in the fuel. 7. The glow plugs are inoperative. 8. The cranking speed is slow. 9. The air cleaner filters are dirty. 10. The fuel filter is clogged. 11. The fuel grade is improper for cold weather use. 12. There is low compression. 13. The injection nozzles or pump are malfunctioning. 14. The ETR solenoid is broken. 	<ol style="list-style-type: none"> 1. Refer to Starting and Stopping the Engine. 2. Fill the tank with fresh fuel. 3. Open the fuel shutoff valve. 4. Drain and flush the fuel system, then add fresh fuel. 5. Clean or replace the fuel line. 6. Bleed the nozzles and check for air leaks at the fuel hose connections and fittings between the fuel tank and the engine. 7. Check the fuse, glow plugs, and wiring. 8. Check the battery, oil viscosity, and starting motor (contact your Authorized Service Dealer). 9. Service the air filters. 10. Replace the fuel filter. 11. Drain the fuel system and replace the fuel filter. Add fresh fuel of the proper grade for ambient temperature conditions. You may need to warm the entire traction unit. 12. Contact your Authorized Service Dealer. 13. Contact your Authorized Service Dealer. 14. Contact your Authorized Service Dealer.

Problem	Possible Cause	Corrective Action
The engine starts, but does not keep running.	<ol style="list-style-type: none"> 1. The fuel tank vent is restricted. 2. Dirt or water is in the fuel system. 3. The fuel filter is clogged. 4. There is air in the fuel. 5. The fuel grade is improper for cold weather use. 6. The spark arrestor screen is clogged. 7. The fuel pump is damaged. 	<ol style="list-style-type: none"> 1. Loosen the cap. If the engine runs with the cap loosened, check the vent lines for blockage. 2. Drain and flush the fuel system; add fresh fuel. 3. Replace the fuel filter. 4. Bleed the nozzles and check for air leaks at fuel hose connections and fittings between the fuel tank and engine. 5. Drain the fuel system and replace the fuel filter. Add fresh fuel of proper grade for ambient temperature conditions. 6. Clean or replace the spark arrestor screen. 7. Contact your Authorized Service Dealer.
The engine runs but knocks or misses.	<ol style="list-style-type: none"> 1. Dirt, water, stale fuel, or incorrect fuel is in the fuel system. 2. The engine is overheating. 3. There is air in the fuel. 4. The injection nozzles are damaged. 5. There is low compression 6. The injection pump timing is incorrect. 7. There is excessive carbon buildup. 8. There is internal wear or damage. 	<ol style="list-style-type: none"> 1. Drain and flush the fuel system; add fresh fuel. 2. Refer to Engine Overheats. 3. Bleed nozzles and check for air leaks at the fuel hose connections and fittings between the fuel tank and engine. 4. Contact your Authorized Service Dealer. 5. Contact your Authorized Service Dealer. 6. Contact your Authorized Service Dealer. 7. Contact your Authorized Service Dealer. 8. Contact your Authorized Service Dealer.
The engine does not idle.	<ol style="list-style-type: none"> 1. The fuel tank vent is restricted. 2. Dirt, water, stale fuel, or incorrect fuel is in the fuel system. 3. The air cleaner filters are dirty. 4. The fuel filter is clogged. 5. There is air in the fuel. 6. The fuel pump is damaged. 7. There is low compression 	<ol style="list-style-type: none"> 1. Loosen the cap. If the engine runs with the cap loosened, check the vent lines for blockage. 2. Drain and flush the fuel system; add fresh fuel. 3. Service the air filters. 4. Replace the fuel filter. 5. Bleed the nozzles and check for air leaks at fuel hose connections and fittings between the fuel tank and engine. 6. Contact your Authorized Service Dealer. 7. Contact your Authorized Service Dealer.

Problem	Possible Cause	Corrective Action
The engine overheats.	<ol style="list-style-type: none"> 1. More coolant is needed. 2. There is restricted air flow to the radiator. 3. The crankcase oil level is incorrect. 4. There is excessive loading. 5. The incorrect fuel is in the fuel system. 6. The thermostat is damaged. 7. The fan belt is loose or broken. 8. Injection timing is incorrect. 9. The coolant pump is damaged. 	<ol style="list-style-type: none"> 1. Check and add coolant. 2. Inspect and clean the side panel screens with every use. 3. Fill or drain to the full mark. 4. Reduce the load and use a lower ground speed. 5. Drain and flush the fuel system; add fresh fuel. 6. Contact your Authorized Service Dealer. 7. Contact your Authorized Service Dealer. 8. Contact your Authorized Service Dealer. 9. Contact your Authorized Service Dealer.
There is excessive black smoke in the exhaust.	<ol style="list-style-type: none"> 1. There is excessive loading. 2. The air cleaner filters are dirty. 3. Incorrect fuel is in the fuel system. 4. The injection pump timing is incorrect. 5. The injection pump is damaged. 6. The injection nozzles are damaged. 	<ol style="list-style-type: none"> 1. Reduce the load and use a lower ground speed. 2. Service the air filters. 3. Drain the fuel system and refill with specified fuel. 4. Contact your Authorized Service Dealer. 5. Contact your Authorized Service Dealer. 6. Contact your Authorized Service Dealer.
There is excessive white smoke in the exhaust.	<ol style="list-style-type: none"> 1. The key was turned to the start position before the glow plug light turned off. 2. The engine temperature is low. 3. The glow plugs are inoperative. 4. The injection pump timing is incorrect. 5. The injection nozzles are damaged. 6. There is low compression 	<ol style="list-style-type: none"> 1. Turn the key to the run position and allow the glow plug light to turn off before starting the engine. 2. Check the thermostat. 3. Check the fuse, glow plugs, and wiring. 4. Contact your Authorized Service Dealer. 5. Contact your Authorized Service Dealer. 6. Contact your Authorized Service Dealer.

Problem	Possible Cause	Corrective Action
The engine loses power.	<ol style="list-style-type: none"> 1. The engine load is excessive. 2. The crankcase oil level is incorrect. 3. The air cleaner filters are dirty. 4. Dirt, water, stale fuel, or incorrect fuel is in the fuel system. 5. The engine is overheating. 6. The spark arrestor screen is clogged. 7. There is air in the fuel. 8. There is low compression 9. The fuel tank vent is restricted. 10. The injection pump timing is incorrect. 11. The injection pump is damaged. 	<ol style="list-style-type: none"> 1. Reduce ground speed. 2. Fill or drain to the full mark. 3. Service the air filters. 4. Drain and flush the fuel system; add fresh fuel. 5. Refer to Engine Overheats. 6. Clean or replace the spark arrestor screen. 7. Bleed the nozzles and check for air leaks at fuel hose connections and fittings between the fuel tank and engine. 8. Contact your Authorized Service Dealer. 9. Contact your Authorized Service Dealer. 10. Contact your Authorized Service Dealer. 11. Contact your Authorized Service Dealer.
The traction unit does not drive.	<ol style="list-style-type: none"> 1. The parking brake is on. 2. The hydraulic fluid level is low. 3. The tow valves are open. 4. The pump and/or wheel motor is damaged. 5. The relief valve is damaged. 	<ol style="list-style-type: none"> 1. Release the parking brake. 2. Add hydraulic fluid to the reservoir. 3. Close the tow valves. 4. Contact your Authorized Service Dealer. 5. Contact your Authorized Service Dealer.

Schematics

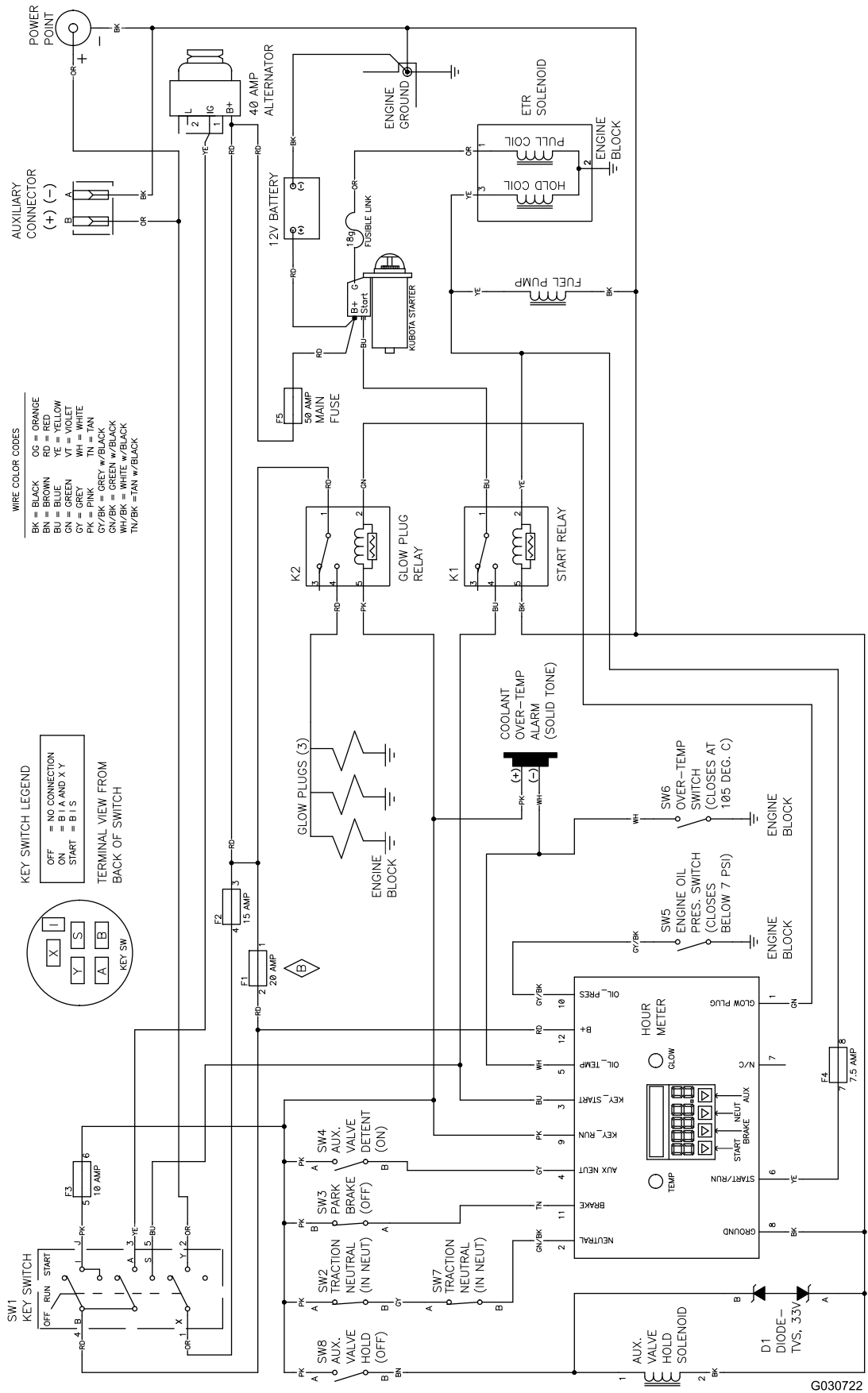

Electrical Schematic (Rev. B)

G030722

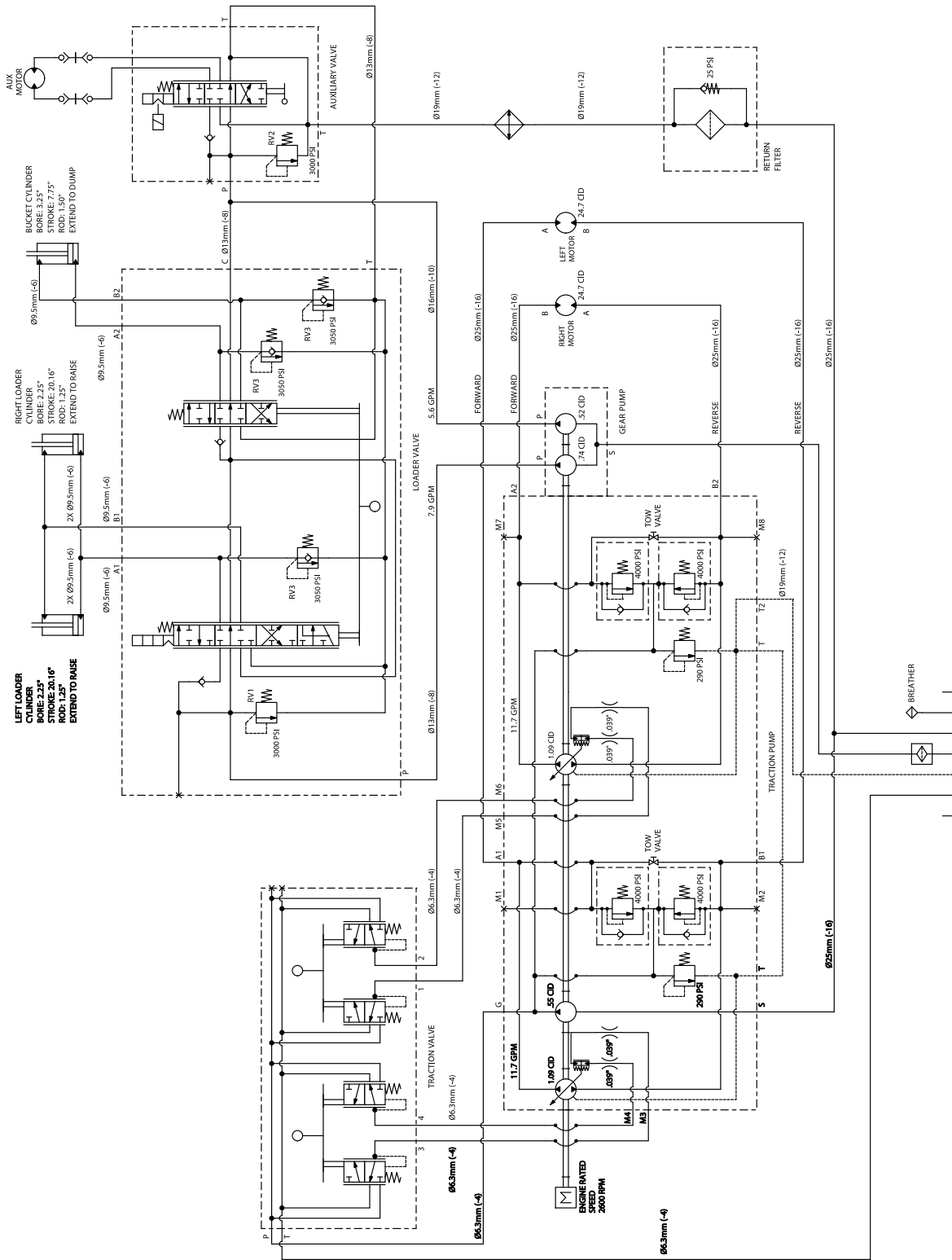

G032315

Hydraulic Schematic (Rev. A)

Notes:

Notes:



Toro Compact Utility Equipment Warranty

A One-Year Limited Warranty

Compact Utility Equipment
(CUE) Products

Conditions and Products Covered

The Toro Company and its affiliate, Toro Warranty Company, pursuant to an agreement between them, jointly warrant your Toro Compact Utility Equipment ("Product") to be free from defects in materials or workmanship. The following time periods apply from the date of purchase:

Products	Warranty Period
Pro Sneak Compact Utility Loaders, Trenchers, Stump Grinders, and Attachments	1 year or 1000 operating hours, whichever occurs first
Kohler Engines	3 years*
All other Engines	2 years*

Where a warrantable condition exists, we will repair the Product at no cost to you including diagnosis, labor, and parts.

*Some engines used on Toro Products are warranted by the engine manufacturer.

Instructions for Obtaining Warranty Service

If you think that your Toro Product contains a defect in materials or workmanship, follow this procedure:

1. Contact any Authorized Toro Compact Utility Equipment (CUE) Service Dealer to arrange service at their dealership. To locate a dealer convenient to you, access our website at www.Toro.com. You may also call our Toro Customer Care Department toll free at the number below.
2. Bring the product and your proof of purchase (sales receipt) to the Service Dealer.
3. If for any reason you are dissatisfied with the Service Dealer's analysis or with the assistance provided, contact us at:

SWS Customer Care Department
Toro Warranty Company
8111 Lyndale Avenue South
Bloomington, MN 55420-1196
Toll Free: 888-384-9940

Owner Responsibilities

You must maintain your Toro Product by following the maintenance procedures described in the *Operator's Manual*. Such routine maintenance, whether performed by a dealer or by you, is at your expense. Parts scheduled for replacement as required maintenance ("Maintenance Parts"), are warranted for the period of time up to the scheduled replacement time for that part. Failure to perform required maintenance and adjustments can be grounds for disallowing a warranty claim.

Items and Conditions Not Covered

Not all product failures or malfunctions that occur during the warranty period are defects in materials or workmanship. This express warranty does not cover the following:

- Product failures which result from the use of non-Toro replacement parts, or from installation and use of add-on, modified, or unapproved accessories
- Product failures which result from failure to perform required maintenance and/or adjustments
- Product failures which result from operating the Product in an abusive, negligent or reckless manner
- Parts subject to consumption through use unless found to be defective. Examples of parts which are consumed, or used up, during normal product operation include, but are not limited to, belts, wipers, spark plugs, tires, filters, gaskets, wear plates, seals, O-rings, drive chains, clutches.
- Failures caused by outside influence. Items considered to be outside influence include, but are not limited to, weather, storage practices, contamination, use of unapproved coolants, lubricants, additives, or chemicals, etc.
- Normal "wear and tear" items. Normal "wear and tear" includes, but is not limited to, worn painted surfaces, scratched decals, etc.
- Repairs necessary due to failure to follow recommended fuel procedure (consult *Operator's Manual* for more details)
 - Removing contaminants from the fuel system is not covered
 - Use of old fuel (more than one month old) or fuel which contains more than 10% ethanol or more than 15% MTBE
 - Failure to drain the fuel system prior to any period of non-use over one month
- Any component covered by a separate manufacturer's warranty
- Pickup and delivery charges

General Conditions

Repair by an Authorized Toro Compact Utility Equipment (CUE) Service Dealer is your sole remedy under this warranty.

Neither The Toro Company nor Toro Warranty Company is liable for indirect, incidental or consequential damages in connection with the use of the Toro Products covered by this warranty, including any cost or expense of providing substitute equipment or service during reasonable periods of malfunction or non-use pending completion of repairs under this warranty. All implied warranties of merchantability and fitness for use are limited to the duration of this express warranty. Some states do not allow exclusions of incidental or consequential damages, or limitations on how long an implied warranty lasts, so the above exclusions and limitations may not apply to you.

This warranty gives you specific legal rights, and you may also have other rights which vary from state to state.

Except for the engine warranty coverage and the Emissions warranty referenced below, if applicable, there is no other express warranty. The Emissions Control System on your Product may be covered by a separate warranty meeting requirements established by the U.S. Environmental Protection Agency (EPA) or the California Air Resources Board (CARB). The hour limitations set forth above do not apply to the Emissions Control System Warranty. Refer to the California Emission Control Warranty Statement supplied with your Product or contained in the engine manufacturer's documentation for details.

Countries Other than the United States or Canada

Customers who have purchased Toro products outside the United States or Canada should contact their Toro Distributor (Dealer) to obtain guarantee policies for your country, province, or state. If for any reason you are dissatisfied with your Distributor's service or have difficulty obtaining guarantee information, contact the Toro importer. If all other remedies fail, you may contact us at Toro Warranty Company.

Australian Consumer Law: Australian customers will find details relating to the Australian Consumer Law either inside the box or at your local Toro Dealer.